

**NMED AIR QUALITY BUREAU
SIGNIFICANT REVISION TO NSR PERMIT
Tagawa Greenhouse Enterprises, LLC
Tagawa Southwest**

Prepared By:

Bill Kluth

Tagawa Greenhouse Enterprises, LLC
17999 County Road 4
Brighton, CO 80603
(303)210-6054

Adam Erenstein – Manager of Consulting Services

TRINITY CONSULTANTS

9400 Holly Ave NE
Building 3, Suite B
Albuquerque, NM 87122
(505) 266-6611

September 2022

Project 223201.0151





9400 Holly Ave NE, Bldg 3, Ste 300, Albuquerque, NM 87122 / P 505.266.6611 / trinityconsultants.com

September 22, 2022

Permit Programs Manager
NMED Air Quality Bureau
525 Camino de los Marquez Suite 1
Santa Fe, NM 87505-1816

*Application for Significant Revision to NSR Permit 2128-M1-R1
Tagawa Greenhouse Enterprises, LLC: Tagawa Southwest*

Permit Programs Manager:

On behalf of Tagawa Greenhouse Enterprises, LLC, we are submitting an application for a Significant Revision to NSR Permit 2128-M1-R1 for Tagawa Southwest facility. This application is being submitted to authorize the addition of two 21 MMBtu/hr boiler units to the facility and removal of 45 MMBtu/hr boiler (Unit 2). Tagawa Greenhouse Enterprises, LLC is submitting this application pursuant to 20.2.72.219.D(1)(a) NMAC.

The format and content of this application are consistent with the Bureau's current policy regarding significant revisions; it is a complete application package using the latest relevant sections of the Universal Application Forms. Please feel free to contact either myself at (505) 266-6611 or Bill Kluth for Tagawa Greenhouse Enterprises, LLC, at (303) 210-6054 if you have any questions regarding this application.

Sincerely,

Adam Erenstein
Manager of Consulting Services

Cc: Pat Lopachin (Tagawa Greenhouse Enterprises, LLC)
Trinity Project File 223201.0151

HEADQUARTERS

12700 Park Central Dr, Ste 2100, Dallas, TX 75251 / P 800.229.6655 / P 972.661.8100 / F 972.385.9203

<p>Mail Application To:</p> <p>New Mexico Environment Department Air Quality Bureau Permits Section 525 Camino de los Marquez, Suite 1 Santa Fe, New Mexico, 87505</p> <p>Phone: (505) 476-4300 Fax: (505) 476-4375 www.env.nm.gov/aqb</p>		<p>For Department use only:</p>
---	--	--

Universal Air Quality Permit Application

Use this application for NOI, NSR, or Title V sources.

Use this application for: the initial application, modifications, technical revisions, and renewals. For technical revisions, complete Sections, 1-A, 1-B, 2-E, 3, 9 and any other sections that are relevant to the requested action; coordination with the Air Quality Bureau permit staff prior to submittal is encouraged to clarify submittal requirements and to determine if more or less than these sections of the application are needed. Use this application for streamline permits as well.

This application is submitted as (check all that apply): Request for a No Permit Required Determination (no fee)
 Updating an application currently under NMED review. Include this page and all pages that are being updated (no fee required).
 Construction Status: Not Constructed Existing Permitted (or NOI) Facility Existing Non-permitted (or NOI) Facility
 Minor Source: a NOI 20.2.73 NMAC 20.2.72 NMAC application or revision 20.2.72.300 NMAC Streamline application
 Title V Source: Title V (new) Title V renewal TV minor mod. TV significant mod. TV Acid Rain: New Renewal
 PSD Major Source: PSD major source (new) minor modification to a PSD source a PSD major modification

Acknowledgements:

I acknowledge that a pre-application meeting is available to me upon request. Title V Operating, Title IV Acid Rain, and NPR applications have no fees.

\$500 NSR application Filing Fee enclosed **OR** The full permit fee associated with 10 fee points (required w/ streamline applications).

Check No.: 652353 in the amount of \$500

I acknowledge the required submittal format for the hard copy application is printed double sided ‘head-to-toe’, 2-hole punched (except the Sect. 2 landscape tables is printed ‘head-to-head’), numbered tab separators. Incl. a copy of the check on a separate page.

I acknowledge there is an annual fee for permits in addition to the permit review fee: www.env.nm.gov/air-quality/permit-fees-2/.

This facility qualifies for the small business fee reduction per 20.2.75.11.C. NMAC. The full \$500.00 filing fee is included with this application and I understand the fee reduction will be calculated in the balance due invoice. The Small Business Certification Form has been previously submitted or is included with this application. (Small Business Environmental Assistance Program Information: www.env.nm.gov/air-quality/small-biz-eap-2/.)

Citation: Please provide the **low level citation** under which this application is being submitted: **20.2.72.219.D(1)(a) NMAC** (e.g. application for a new minor source would be 20.2.72.200.A NMAC, one example for a Technical Permit Revision is 20.2.72.219.B.1.b NMAC, a Title V acid rain application would be: 20.2.70.200.C NMAC)

Section 1 – Facility Information

Section 1-A: Company Information		AI # if known (see 1 st 3 to 5 #s of permit IDEA ID No.): 1576	Updating Permit/NOI #: 2128-M1
1	Facility Name: Tagawa Southwest	Plant primary SIC Code (4 digits): 0182	
		Plant NAIC code (6 digits): 111419	
a	Facility Street Address (If no facility street address, provide directions from a prominent landmark): 1459 State Road 542, Estancia, NM 87016		
2	Plant Operator Company Name: Tagawa Greenhouse Enterprises LLC	Phone/Fax: (303) 210-6054 / N/A	
a	Plant Operator Address: 17999 County Road 4, Brighton, CO 80603		
b	Plant Operator's New Mexico Corporate ID or Tax ID: 4272647		

3	Plant Owner(s) name(s): Bill Kluth	Phone/Fax: (303) 210-6054 / N/A
a	Plant Owner(s) Mailing Address(s): 17999 County Road 4, Brighton, CO 80603	
4	Bill To (Company): Tagawa Greenhouse Enterprises LLC	Phone/Fax: (303) 210-6054 / N/A
a	Mailing Address: 17999 County Road 4, Brighton, CO 80603	E-mail: bkluth@tagawas.com
5	<input checked="" type="checkbox"/> Preparer: Trinity Consultants <input checked="" type="checkbox"/> Consultant: Adam Erenstein	Phone/Fax: (505)266-6611 / N/A
a	Mailing Address: 9400 Holly Ave NE Building 3, Suite B, Albuquerque, NM 87122	E-mail: aerenstein@trinityconsultants.com
6	Plant Operator Contact: Pat Lopachin	Phone/Fax: (704) 274-6717 / N/A
a	Address: 17999 County Road 4, Brighton, CO 80603	E-mail: plopachin@tagawas.com
7	Air Permit Contact: Bill Kluth	Title: Greenhouse Operations Manager
a	E-mail: bkluth@tagawas.com	Phone/Fax: (303) 210-6054 / N/A
b	Mailing Address: 17999 County Road 4, Brighton, CO 80603	
c	The designated Air permit Contact will receive all official correspondence (i.e. letters, permits) from the Air Quality Bureau.	

Section 1-B: Current Facility Status

1.a	Has this facility already been constructed? <input checked="" type="checkbox"/> Yes <input type="checkbox"/> No	1.b If yes to question 1.a, is it currently operating in New Mexico? <input checked="" type="checkbox"/> Yes <input type="checkbox"/> No
2	If yes to question 1.a, was the existing facility subject to a Notice of Intent (NOI) (20.2.73 NMAC) before submittal of this application? <input type="checkbox"/> Yes <input checked="" type="checkbox"/> No	If yes to question 1.a, was the existing facility subject to a construction permit (20.2.72 NMAC) before submittal of this application? <input checked="" type="checkbox"/> Yes <input type="checkbox"/> No
3	Is the facility currently shut down? <input type="checkbox"/> Yes <input checked="" type="checkbox"/> No	If yes, give month and year of shut down (MM/YY): N/A
4	Was this facility constructed before 8/31/1972 and continuously operated since 1972? <input type="checkbox"/> Yes <input checked="" type="checkbox"/> No	
5	If Yes to question 3, has this facility been modified (see 20.2.72.7.P NMAC) or the capacity increased since 8/31/1972? <input type="checkbox"/> Yes <input type="checkbox"/> No <input checked="" type="checkbox"/> N/A	
6	Does this facility have a Title V operating permit (20.2.70 NMAC)? <input type="checkbox"/> Yes <input checked="" type="checkbox"/> No	If yes, the permit No. is: N/A
7	Has this facility been issued a No Permit Required (NPR)? <input type="checkbox"/> Yes <input checked="" type="checkbox"/> No	If yes, the NPR No. is: N/A
8	Has this facility been issued a Notice of Intent (NOI)? <input type="checkbox"/> Yes <input checked="" type="checkbox"/> No	If yes, the NOI No. is: N/A
9	Does this facility have a construction permit (20.2.72/20.2.74 NMAC)? <input checked="" type="checkbox"/> Yes <input type="checkbox"/> No	If yes, the permit No. is: 2128-M1-R1
10	Is this facility registered under a General permit (GCP-1, GCP-2, etc.)? <input type="checkbox"/> Yes <input checked="" type="checkbox"/> No	If yes, the register No. is: N/A

Section 1-C: Facility Input Capacity & Production Rate

1	What is the facility's maximum input capacity, specify units (reference here and list capacities in Section 20, if more room is required)			
a	Current	Hourly: N/A	Daily: 24 hr/day	Annually: 8760 hr/yr
b	Proposed	Hourly: N/A	Daily: 24 hr/day	Annually: 8760 hr/yr
2	What is the facility's maximum production rate, specify units (reference here and list capacities in Section 20, if more room is required)			
a	Current	Hourly: N/A	Daily: 24 hr/day	Annually: 8760 hr/yr
b	Proposed	Hourly: N/A	Daily: 24 hr/day	Annually: 8760 hr/yr

Section 1-D: Facility Location Information

1	Section: S10	Range: 8E	Township: 5N	County: Torrance	Elevation (ft): 6149 ft
2	UTM Zone: <input type="checkbox"/> 12 or <input checked="" type="checkbox"/> 13			Datum: <input type="checkbox"/> NAD 27 <input type="checkbox"/> NAD 83 <input checked="" type="checkbox"/> WGS 84	
a	UTM E (in meters, to nearest 10 meters): 400,810 m E			UTM N (in meters, to nearest 10 meters): 3,837,090 m N	
b	AND Latitude (deg., min., sec.): 34°40'15.57"N			Longitude (deg., min., sec.): 106° 4'57.54"W	
3	Name and zip code of nearest New Mexico town: Estancia, NM 87016				
4	Detailed Driving Instructions from nearest NM town (attach a road map if necessary): From Estancia, NM drive south for 6.3 miles on Highway 41. Make a right on 542 and continue for 1 mile. Make a right and continue for 0.4 miles. Facility will be ahead.				
5	The facility is 5.3 miles southwest of Estancia, NM.				
6	Status of land at facility (check one): <input checked="" type="checkbox"/> Private <input type="checkbox"/> Indian/Pueblo <input type="checkbox"/> Federal BLM <input type="checkbox"/> Federal Forest Service <input type="checkbox"/> Other (specify)				
7	List all municipalities, Indian tribes, and counties within a ten (10) mile radius (20.2.72.203.B.2 NMAC) of the property on which the facility is proposed to be constructed or operated: Estancia, NM and Willard, NM				
8	20.2.72 NMAC applications only : Will the property on which the facility is proposed to be constructed or operated be closer than 50 km (31 miles) to other states, Bernalillo County, or a Class I area (see www.env.nm.gov/air-quality/modeling-publications/)? <input type="checkbox"/> Yes <input checked="" type="checkbox"/> No (20.2.72.206.A.7 NMAC) If yes, list all with corresponding distances in kilometers: N/A				
9	Name nearest Class I area: Bosque del Apache				
10	Shortest distance (in km) from facility boundary to the boundary of the nearest Class I area (to the nearest 10 meters): 108 km				
11	Distance (meters) from the perimeter of the Area of Operations (AO is defined as the plant site inclusive of all disturbed lands, including mining overburden removal areas) to nearest residence, school or occupied structure: 760 meters				
12	Method(s) used to delineate the Restricted Area: Fencing "Restricted Area" is an area to which public entry is effectively precluded. Effective barriers include continuous fencing, continuous walls, or other continuous barriers approved by the Department, such as rugged physical terrain with steep grade that would require special equipment to traverse. If a large property is completely enclosed by fencing, a restricted area within the property may be identified with signage only. Public roads cannot be part of a Restricted Area.				
13	Does the owner/operator intend to operate this source as a portable stationary source as defined in 20.2.72.7.X NMAC? <input type="checkbox"/> Yes <input checked="" type="checkbox"/> No A portable stationary source is not a mobile source, such as an automobile, but a source that can be installed permanently at one location or that can be re-installed at various locations, such as a hot mix asphalt plant that is moved to different job sites.				
14	Will this facility operate in conjunction with other air regulated parties on the same property? <input checked="" type="checkbox"/> No <input type="checkbox"/> Yes If yes, what is the name and permit number (if known) of the other facility? N/A				

Section 1-E: Proposed Operating Schedule (The 1-E.1 & 1-E.2 operating schedules may become conditions in the permit.)

1	Facility maximum operating ($\frac{\text{hours}}{\text{day}}$): 24	($\frac{\text{days}}{\text{week}}$): 7	($\frac{\text{weeks}}{\text{year}}$): 52	($\frac{\text{hours}}{\text{year}}$): 8760
2	Facility's maximum daily operating schedule (if less than 24 $\frac{\text{hours}}{\text{day}}$)? Start: N/A		<input type="checkbox"/> AM <input type="checkbox"/> PM	End: N/A <input type="checkbox"/> AM <input type="checkbox"/> PM
3	Month and year of anticipated start of construction: N/A			
4	Month and year of anticipated construction completion: N/A			
5	Month and year of anticipated startup of new or modified facility: Upon issuance of permit.			
6	Will this facility operate at this site for more than one year? <input checked="" type="checkbox"/> Yes <input type="checkbox"/> No			

Section 1-F: Other Facility Information

1	Are there any current Notice of Violations (NOV), compliance orders, or any other compliance or enforcement issues related to this facility? <input type="checkbox"/> Yes <input checked="" type="checkbox"/> No If yes, specify:
---	---

a	If yes, NOV date or description of issue: N/A		NOV Tracking No: N/A
b	Is this application in response to any issue listed in 1-F, 1 or 1a above? <input type="checkbox"/> Yes <input checked="" type="checkbox"/> No If Yes, provide the 1c & 1d info below: N/A		
c	Document Title: N/A	Date: N/A	Requirement # (or page # and paragraph #): N/A
d	Provide the required text to be inserted in this permit: N/A		
2	Is air quality dispersion modeling or modeling waiver being submitted with this application? <input checked="" type="checkbox"/> Yes <input type="checkbox"/> No		
3	Does this facility require an "Air Toxics" permit under 20.2.72.400 NMAC & 20.2.72.502, Tables A and/or B? <input type="checkbox"/> Yes <input checked="" type="checkbox"/> No		
4	Will this facility be a source of federal Hazardous Air Pollutants (HAP)? <input checked="" type="checkbox"/> Yes <input type="checkbox"/> No		
a	If Yes, what type of source? <input type="checkbox"/> Major (<input type="checkbox"/> ≥10 tpy of any single HAP OR <input type="checkbox"/> ≥25 tpy of any combination of HAPS) OR <input checked="" type="checkbox"/> Minor (<input type="checkbox"/> <10 tpy of any single HAP AND <input checked="" type="checkbox"/> <25 tpy of any combination of HAPS)		
5	Is any unit exempt under 20.2.72.202.B.3 NMAC? <input type="checkbox"/> Yes <input checked="" type="checkbox"/> No		
a	If yes, include the name of company providing commercial electric power to the facility: <u>Central New Mexico Coop</u> Commercial power is purchased from a commercial utility company, which specifically does not include power generated on site for the sole purpose of the user.		

Section 1-G: Streamline Application (This section applies to 20.2.72.300 NMAC Streamline applications only)

1	<input type="checkbox"/> I have filled out Section 18, "Addendum for Streamline Applications." <input checked="" type="checkbox"/> N/A (This is not a Streamline application.)
---	--

Section 1-I – Submittal Requirements

Each 20.2.73 NMAC (NOI), a 20.2.70 NMAC (Title V), a 20.2.72 NMAC (NSR minor source), or 20.2.74 NMAC (PSD) application package shall consist of the following:

Hard Copy Submittal Requirements:

- 1) One hard copy **original signed and notarized application package printed double sided 'head-to-toe' 2-hole punched** as we bind the document on top, not on the side; except Section 2 (landscape tables), which should be **head-to-head**. Please use **numbered tab separators** in the hard copy submittal(s) as this facilitates the review process. For NOI submittals only, hard copies of UA1, Tables 2A, 2D & 2F, Section 3 and the signed Certification Page are required. **Please include a copy of the check on a separate page.**
- 2) If the application is for a minor NSR, PSD, NNSR, or Title V application, include one working hard **copy** for Department use. This **copy** should be printed in book form, 3-hole punched, and **must be double sided**. Note that this is in addition to the head-to-toe 2-hole punched copy required in 1) above. Minor NSR Technical Permit revisions (20.2.72.219.B NMAC) only need to fill out Sections 1-A, 1-B, 3, and should fill out those portions of other Section(s) relevant to the technical permit revision. TV Minor Modifications need only fill out Sections 1-A, 1-B, 1-H, 3, and those portions of other Section(s) relevant to the minor modification. NMED may require additional portions of the application to be submitted, as needed.
- 3) The entire NOI or Permit application package, including the full modeling study, should be submitted electronically. Electronic files for applications for NOIs, any type of General Construction Permit (GCP), or technical revisions to NSRs must be submitted with compact disk (CD) or digital versatile disc (DVD). For these permit application submittals, **two CD** copies are required (in sleeves, not crystal cases, please), with additional CD copies as specified below. NOI applications require only a **single CD** submittal. Electronic files for other New Source Review (construction) permits/permit modifications or Title V permits/permit modifications can be submitted on CD/DVD or sent through AQB's secure file transfer service.

Electronic files sent by (check one):

- CD/DVD attached to paper application
- secure electronic transfer.

Air Permit Contact Name: Adam Erenstein, Email: aerenstein@trinityconsultants.com ; Phone number: 505-266-6611.

- a. If the file transfer service is chosen by the applicant, after receipt of the application, the Bureau will email the applicant with instructions for submitting the electronic files through a secure file transfer service. Submission of the electronic files through the file transfer service needs to be completed within 3 business days after the invitation is received, so the applicant should ensure that the files are ready when sending the hard copy of the application. The applicant will not need a password to complete the transfer. **Do not use the file transfer service for NOIs, any type of GCP, or technical revisions to NSR permits.**
- 4) Optionally, the applicant may submit the files with the application on compact disk (CD) or digital versatile disc (DVD) following the instructions above and the instructions in 5 for applications subject to PSD review.
- 5) If **air dispersion modeling** is required by the application type, include the **NMED Modeling Waiver** and/or electronic air dispersion modeling report, input, and output files. The dispersion modeling **summary report only** should be submitted as hard copy(ies) unless otherwise indicated by the Bureau.
- 6) If the applicant submits the electronic files on CD and the application is subject to PSD review under 20.2.74 NMAC (PSD) or NNSR under 20.2.79 NMC include,
- one additional CD copy for US EPA,
 - one additional CD copy for each federal land manager affected (NPS, USFS, FWS, USDI) and,
 - one additional CD copy for each affected regulatory agency other than the Air Quality Bureau.

If the application is submitted electronically through the secure file transfer service, these extra CDs do not need to be submitted.

Electronic Submittal Requirements [in addition to the required hard copy(ies)]:

- All required electronic documents shall be submitted as 2 separate CDs or submitted through the AQB secure file transfer service. Submit a single PDF document of the entire application as submitted and the individual documents comprising the application.
- The documents should also be submitted in Microsoft Office compatible file format (Word, Excel, etc.) allowing us to access the text and formulas in the documents (copy & paste). Any documents that cannot be submitted in a Microsoft Office compatible format shall be saved as a PDF file from within the electronic document that created the file. If you are unable to provide Microsoft office compatible electronic files or internally generated PDF files of files (items that were not created electronically: i.e. brochures, maps, graphics, etc.), submit these items in hard copy format. We must be able to review the formulas and inputs that calculated the emissions.
- It is preferred that this application form be submitted as 4 electronic files (**3 MSWord docs**: Universal Application section 1 [UA1], Universal Application section 3-19 [UA3], and Universal Application 4, the modeling report [UA4]) and **1 Excel file** of the tables (Universal Application section 2 [UA2]). Please include as many of the 3-19 Sections as practical in a single MS Word electronic document. Create separate electronic file(s) if a single file becomes too large or if portions must be saved in a file format other than MS Word.
- The **electronic file names** shall be a maximum of 25 characters long (including spaces, if any). The format of the electronic Universal Application shall be in the format: "A-3423-FacilityName". The "A" distinguishes the file as an application submittal, as opposed to other documents the Department itself puts into the database. Thus, all electronic application submittals should begin with "A-". Modifications to existing facilities should use the **core permit number** (i.e. '3423') the Department assigned to the facility as the next 4 digits. Use 'XXXX' for new facility applications. The format of any separate electronic submittals (additional submittals such as non-Word attachments, re-submittals, application updates) and Section document shall be in the format: "A-3423-9-description", where "9" stands for the **section #** (in this case Section 9-Public Notice). Please refrain, as much as possible, from submitting any scanned documents as this file format is extremely large, which uses up too much storage capacity in our database. Please take the time to fill out the **header information** throughout all submittals as this will identify any loose pages, including the Application Date (date submitted) & Revision number (0 for original, 1, 2, etc.; which will help keep track of subsequent partial update(s) to the original submittal. Do not use special symbols (#, @, etc.) in file names. The footer information should not be modified by the applicant.

Table of Contents

Section 1:	General Facility Information
Section 2:	Tables
Section 3:	Application Summary
Section 4:	Process Flow Sheet
Section 5:	Plot Plan Drawn to Scale
Section 6:	All Calculations

- Section 7: Information Used to Determine Emissions**
- Section 8: Map(s)**
- Section 9: Proof of Public Notice**
- Section 10: Written Description of the Routine Operations of the Facility**
- Section 11: Source Determination**
- Section 12: PSD Applicability Determination for All Sources & Special Requirements for a PSD Application**
- Section 13: Discussion Demonstrating Compliance with Each Applicable State & Federal Regulation**
- Section 14: Operational Plan to Mitigate Emissions**
- Section 15: Alternative Operating Scenarios**
- Section 16: Air Dispersion Modeling**
- Section 17: Compliance Test History**
- Section 18: Addendum for Streamline Applications (streamline applications only)**
- Section 19: Requirements for the Title V (20.2.70 NMAC) Program (Title V applications only)**
- Section 20: Other Relevant Information**
- Section 21: Addendum for Landfill Applications**
- Section 22: Certification Page**

Change Log – Do **not** submit this page with your application.

If you are using a form older than the most current form posted on the website, you are required to incorporate the changes listed. Periodically, AQB will announce when older form versions will no longer be accepted.

Version Date	Changes Incorporated
4/1/2021	Current version of this form. Older versions are not accepted.

Table 2-A: Regulated Emission Sources

Unit and stack numbering must correspond throughout the application package. If applying for a NOI under 20.2.73 NMAC, equipment exemptions under 2.72.202 NMAC do not apply.

Unit Number ¹	Source Description	Make	Model #	Serial #	Manufacturer's Rated Capacity ³ (Specify Units)	Requested Permitted Capacity ³ (Specify Units)	Date of Manufacture ²	Controlled by Unit #	Source Classification Code (SCC)	For Each Piece of Equipment, Check One	RICE Ignition Type (CI, SI, 4SLB, 4SRB, 2SLB) ⁴	Replacing Unit No.
							Date of Construction/Reconstruction ²	Emissions vented to Stack #				
1	Boiler	Thermeta	LN 100 UFGO	1032-0412	45 MMBtu/hr	45 MMBtu/hr	October 2004	1	10100602	<input checked="" type="checkbox"/> Existing (unchanged) <input type="checkbox"/> To be Removed <input type="checkbox"/> New/Additional <input type="checkbox"/> Replacement Unit <input type="checkbox"/> To Be Modified <input type="checkbox"/> To be Replaced	N/A	
							January 2005	1				
2	Boiler	Thermeta	LN 100 UFGO	1033-0412	45 MMBtu/hr	45 MMBtu/hr	October 2004	2	10100602	<input type="checkbox"/> Existing (unchanged) <input checked="" type="checkbox"/> To be Removed <input type="checkbox"/> New/Additional <input type="checkbox"/> Replacement Unit <input type="checkbox"/> To Be Modified <input type="checkbox"/> To be Replaced	N/A	
							January 2005	2				
2	Boiler	John Zink	F18.1-G0-200	S2500-150-45	21 MMBtu/hr	21 MMBtu/hr	2003	2	10100602	<input type="checkbox"/> Existing (unchanged) <input type="checkbox"/> To be Removed <input checked="" type="checkbox"/> New/Additional <input type="checkbox"/> Replacement Unit <input type="checkbox"/> To Be Modified <input type="checkbox"/> To be Replaced	N/A	
							TBD	2				
3	Boiler	Power Flame Inc.	CM10A-G0-30	S2500-15-7	21 MMBtu/hr	21 MMBtu/hr	2004	3	10100602	<input type="checkbox"/> Existing (unchanged) <input type="checkbox"/> To be Removed <input checked="" type="checkbox"/> New/Additional <input type="checkbox"/> Replacement Unit <input type="checkbox"/> To Be Modified <input type="checkbox"/> To be Replaced	N/A	
							TBD	3				
										<input type="checkbox"/> Existing (unchanged) <input type="checkbox"/> To be Removed <input type="checkbox"/> New/Additional <input type="checkbox"/> Replacement Unit <input type="checkbox"/> To Be Modified <input type="checkbox"/> To be Replaced		
										<input type="checkbox"/> Existing (unchanged) <input type="checkbox"/> To be Removed <input type="checkbox"/> New/Additional <input type="checkbox"/> Replacement Unit <input type="checkbox"/> To Be Modified <input type="checkbox"/> To be Replaced		
										<input type="checkbox"/> Existing (unchanged) <input type="checkbox"/> To be Removed <input type="checkbox"/> New/Additional <input type="checkbox"/> Replacement Unit <input type="checkbox"/> To Be Modified <input type="checkbox"/> To be Replaced		
										<input type="checkbox"/> Existing (unchanged) <input type="checkbox"/> To be Removed <input type="checkbox"/> New/Additional <input type="checkbox"/> Replacement Unit <input type="checkbox"/> To Be Modified <input type="checkbox"/> To be Replaced		
										<input type="checkbox"/> Existing (unchanged) <input type="checkbox"/> To be Removed <input type="checkbox"/> New/Additional <input type="checkbox"/> Replacement Unit <input type="checkbox"/> To Be Modified <input type="checkbox"/> To be Replaced		
										<input type="checkbox"/> Existing (unchanged) <input type="checkbox"/> To be Removed <input type="checkbox"/> New/Additional <input type="checkbox"/> Replacement Unit <input type="checkbox"/> To Be Modified <input type="checkbox"/> To be Replaced		
										<input type="checkbox"/> Existing (unchanged) <input type="checkbox"/> To be Removed <input type="checkbox"/> New/Additional <input type="checkbox"/> Replacement Unit <input type="checkbox"/> To Be Modified <input type="checkbox"/> To be Replaced		
										<input type="checkbox"/> Existing (unchanged) <input type="checkbox"/> To be Removed <input type="checkbox"/> New/Additional <input type="checkbox"/> Replacement Unit <input type="checkbox"/> To Be Modified <input type="checkbox"/> To be Replaced		
										<input type="checkbox"/> Existing (unchanged) <input type="checkbox"/> To be Removed <input type="checkbox"/> New/Additional <input type="checkbox"/> Replacement Unit <input type="checkbox"/> To Be Modified <input type="checkbox"/> To be Replaced		

¹ Unit numbers must correspond to unit numbers in the previous permit unless a complete cross reference table of all units in both permits is provided.

² Specify dates required to determine regulatory applicability.

³ To properly account for power conversion efficiencies, generator set rated capacity shall be reported as the rated capacity of the engine in horsepower, not the kilowatt capacity of the generator set.

⁴ "4SLB" means four stroke lean burn engine, "4SRB" means four stroke rich burn engine, "2SLB" means two stroke lean burn engine, "CI" means compression ignition, and "SI" means spark ignition

Table 2-B: Insignificant Activities¹ (20.2.70 NMAC) OR Exempted Equipment (20.2.72 NMAC)

All 20.2.70 NMAC (Title V) applications must list all Insignificant Activities in this table. All 20.2.72 NMAC applications must list Exempted Equipment in this table. If equipment listed on this table is exempt under 20.2.72.202.B.5, include emissions calculations and emissions totals for 202.B.5 "similar functions" units, operations, and activities in Section 6, Calculations. Equipment and activities exempted under 20.2.72.202 NMAC may not necessarily be Insignificant under 20.2.70 NMAC (and vice versa). Unit & stack numbering must be consistent throughout the application package. Per Exemptions Policy 02-012.00 (see http://www.env.nm.gov/aqb/permit/aqb_pol.html), 20.2.72.202.B NMAC Exemptions do not apply, but 20.2.72.202.A NMAC exemptions do apply to NOI facilities under 20.2.73 NMAC. List 20.2.72.301.D.4 NMAC Auxiliary Equipment for Streamline applications in Table 2-A. The List of Insignificant Activities (for TV) can be found online at <https://www.env.nm.gov/wp-content/uploads/sites/2/2017/10/InsignificantListTitleV.pdf>. TV sources may elect to enter both TV Insignificant Activities and Part 72 Exemptions on this form.

Unit Number	Source Description	Manufacturer	Model No.	Max Capacity	List Specific 20.2.72.202 NMAC Exemption (e.g. 20.2.72.202.B.5)	Date of Manufacture /Reconstruction ²	For Each Piece of Equipment, Check One
			Serial No.	Capacity Units	Insignificant Activity citation (e.g. IA List Item #1.a)	Date of Installation /Construction ²	
3	Generator	MQ Power	Whisperwatt Generator	354 HP	20.2.72.202.B.3	N/A	<input checked="" type="checkbox"/> Existing (unchanged) <input type="checkbox"/> To be Removed <input type="checkbox"/> New/Additional <input type="checkbox"/> Replacement Unit <input type="checkbox"/> To Be Modified <input type="checkbox"/> To be Replaced
				354 HP		N/A	
TK-1	Diesel Storage Tank	N/A	N/A	N/A	20.2.72.202.B.5	N/A	<input checked="" type="checkbox"/> Existing (unchanged) <input type="checkbox"/> To be Removed <input type="checkbox"/> New/Additional <input type="checkbox"/> Replacement Unit <input type="checkbox"/> To Be Modified <input type="checkbox"/> To be Replaced
			N/A	N/A		N/A	
							<input type="checkbox"/> Existing (unchanged) <input type="checkbox"/> To be Removed <input type="checkbox"/> New/Additional <input type="checkbox"/> Replacement Unit <input type="checkbox"/> To Be Modified <input type="checkbox"/> To be Replaced
							<input type="checkbox"/> Existing (unchanged) <input type="checkbox"/> To be Removed <input type="checkbox"/> New/Additional <input type="checkbox"/> Replacement Unit <input type="checkbox"/> To Be Modified <input type="checkbox"/> To be Replaced
							<input type="checkbox"/> Existing (unchanged) <input type="checkbox"/> To be Removed <input type="checkbox"/> New/Additional <input type="checkbox"/> Replacement Unit <input type="checkbox"/> To Be Modified <input type="checkbox"/> To be Replaced
							<input type="checkbox"/> Existing (unchanged) <input type="checkbox"/> To be Removed <input type="checkbox"/> New/Additional <input type="checkbox"/> Replacement Unit <input type="checkbox"/> To Be Modified <input type="checkbox"/> To be Replaced
							<input type="checkbox"/> Existing (unchanged) <input type="checkbox"/> To be Removed <input type="checkbox"/> New/Additional <input type="checkbox"/> Replacement Unit <input type="checkbox"/> To Be Modified <input type="checkbox"/> To be Replaced
							<input type="checkbox"/> Existing (unchanged) <input type="checkbox"/> To be Removed <input type="checkbox"/> New/Additional <input type="checkbox"/> Replacement Unit <input type="checkbox"/> To Be Modified <input type="checkbox"/> To be Replaced
							<input type="checkbox"/> Existing (unchanged) <input type="checkbox"/> To be Removed <input type="checkbox"/> New/Additional <input type="checkbox"/> Replacement Unit <input type="checkbox"/> To Be Modified <input type="checkbox"/> To be Replaced
							<input type="checkbox"/> Existing (unchanged) <input type="checkbox"/> To be Removed <input type="checkbox"/> New/Additional <input type="checkbox"/> Replacement Unit <input type="checkbox"/> To Be Modified <input type="checkbox"/> To be Replaced

¹ Insignificant activities exempted due to size or production rate are defined in 20.2.70.300.D.6, 20.2.70.7.Q NMAC, and the NMED/AQB List of Insignificant Activities, dated September 15, 2008. Emissions from these insignificant activities do not need to be reported, unless specifically requested.

² Specify date(s) required to determine regulatory applicability.

Table 2-C: Emissions Control Equipment

Unit and stack numbering must correspond throughout the application package. Only list control equipment for TAPs if the TAP's maximum uncontrolled emissions rate is over its respective threshold as listed in 20.2.72 NMAC, Subpart V, Tables A and B. In accordance with 20.2.72.203.A(3) and (8) NMAC, 20.2.70.300.D(5)(b) and (e) NMAC, and 20.2.73.200.B(7) NMAC, the permittee shall report all control devices and list each pollutant controlled by the control device regardless if the applicant takes credit for the reduction in emissions.

Control Equipment Unit No.	Control Equipment Description	Date Installed	Controlled Pollutant(s)	Controlling Emissions for Unit Number(s) ¹	Efficiency (% Control by Weight)	Method used to Estimate Efficiency

¹ List each control device on a separate line. For each control device, list all emission units controlled by the control device.

Table 2-D: Maximum Emissions (under normal operating conditions)

[X] This Table was intentionally left blank because it would be identical to Table 2-E.

Maximum Emissions are the emissions at maximum capacity and prior to (in the absence of) pollution control, emission-reducing process equipment, or any other emission reduction. Calculate the hourly emissions using the worst case hourly emissions for each pollutant. For each pollutant, calculate the annual emissions as if the facility were operating at maximum plant capacity without pollution controls for 8760 hours per year, unless otherwise approved by the Department. List Hazardous Air Pollutants (HAP) & Toxic Air Pollutants (TAPs) in Table 2-I. Unit & stack numbering must be consistent throughout the application package. Fill all cells in this table with the emission numbers or a "-" symbol. A "--" symbol indicates that emissions of this pollutant are not expected. Numbers shall be expressed to at least 2 decimal points (e.g. 0.41, 1.41, or 1.41E-4).

Table with columns for Unit No., NOx, CO, VOC, SOx, PM1, PM10, PM2.5, H2S, and Lead. Each pollutant column has sub-columns for lb/hr and ton/yr. The table is mostly blank, ending with a Totals row.

1 Condensable Particulate Matter: Include condensable particulate matter emissions for PM10 and PM2.5 if the source is a combustion source. Do not include condensable particulate matter for PM unless PM is set equal to PM10 and PM2.5. Particulate matter (PM) is not subject to an ambient air quality standard, but PM is a regulated air pollutant under PSD (20.2.74 NMAC) and Title V (20.2.70 NMAC).

Table 2-E: Requested Allowable Emissions

Unit & stack numbering must be consistent throughout the application package. Fill all cells in this table with the emission numbers or a "-" symbol. A "--" symbol indicates that emissions of this pollutant are not expected. Numbers shall be expressed to at least 2 decimal points (e.g. 0.41, 1.41, or 1.41E⁻⁴).

Unit No.	NOx		CO		VOC		SOx		PM ¹		PM10 ¹		PM2.5 ¹		H ₂ S		Lead	
	lb/hr	ton/yr	lb/hr	ton/yr	lb/hr	ton/yr	lb/hr	ton/yr	lb/hr	ton/yr	lb/hr	ton/yr	lb/hr	ton/yr	lb/hr	ton/yr	lb/hr	ton/yr
1 (Natural Gas)	2.21	9.66	3.71	16.23	0.24	1.06	0.25	1.10	0.34	1.47	0.34	1.47	0.34	1.47	-	-	-	-
1 (Diesel) ²	3.04	0.02	1.52	0.01	0.06	0.00	0.08	0.00	0.61	0.00	0.61	0.00	0.61	0.00	-	-	-	-
2 (Natural Gas)	2.06	9.02	1.73	7.57	0.11	1.06	0.12	0.52	0.16	0.69	0.16	0.69	0.16	0.69	-	-	-	-
2 (Diesel) ²	3.60	0.02	0.75	0.00	0.03	0.00	0.04	0.00	0.30	0.00	0.30	0.00	0.30	0.00				
3 (Natural Gas)	2.06	9.02	1.73	7.57	0.11	1.06	0.12	0.52	0.16	0.69	0.16	0.69	0.16	0.69				
3 (Diesel) ²	3.60	0.02	0.75	0.00	0.03	0.00	0.04	0.00	0.30	0.00	0.30	0.00	0.30	0.00				
Totals	10.24	27.75	7.16	31.40	0.47	3.19	0.49	2.14	1.21	2.85	1.21	2.85	1.21	2.85	-	-	-	-

¹ **Condensable Particulate Matter:** Include condensable particulate matter emissions for PM10 and PM2.5 if the source is a combustion source. Do not include condensable particulate matter for PM unless PM is set equal to PM10 and PM2.5. Particulate matter (PM) is not subject to an ambient air quality standard, but it is a regulated air pollutant under PSD (20.2.74 NMAC) and Title V (20.2.70 NMAC).

² Alternative fuel is based on 10 hours of operation per year.

Table 2-F: Additional Emissions during Startup, Shutdown, and Routine Maintenance (SSM)

This table is intentionally left blank since all emissions at this facility due to routine or predictable startup, shutdown, or scheduled maintenance are no higher than those listed in Table 2-E and a malfunction emission limit is not already permitted or requested. If you are required to report GHG emissions as described in Section 6a, include any GHG emissions during Startup, Shutdown, and/or Scheduled Maintenance (SSM) in Table 2-P. Provide an explanations of SSM emissions in Section 6 and 6a.

All applications for facilities that have emissions during routine our predictable startup, shutdown or scheduled maintenance (SSM)¹, including NOI applications, must include in this table the Maximum Emissions during routine or predictable startup, shutdown and scheduled maintenance (20.2.7 NMAC, 20.2.72.203.A.3 NMAC, 20.2.73.200.D.2 NMAC). In Section 6 and 6a, provide emissions calculations for all SSM emissions reported in this table. Refer to "Guidance for Submittal of Startup, Shutdown, Maintenance Emissions in Permit Applications (https://www.env.nm.gov/aqb/permit/aqb_pol.html) for more detailed instructions. Numbers shall be expressed to at least 2 decimal points (e.g. 0.41, 1.41, or 1.41E-4).

Unit No.	NOx		CO		VOC		SOx		PM ²		PM10 ²		PM2.5 ²		H ₂ S		Lead	
	lb/hr	ton/yr	lb/hr	ton/yr	lb/hr	ton/yr	lb/hr	ton/yr	lb/hr	ton/yr	lb/hr	ton/yr	lb/hr	ton/yr	lb/hr	ton/yr	lb/hr	ton/yr
Totals																		

¹ For instance, if the short term steady-state Table 2-E emissions are 5 lb/hr and the SSM rate is 12 lb/hr, enter 7 lb/hr in this table. If the annual steady-state Table 2-E emissions are 21.9 TPY, and the number of scheduled SSM events result in annual emissions of 31.9 TPY, enter 10.0 TPY in the table below.

² **Condensable Particulate Matter:** Include condensable particulate matter emissions for PM10 and PM2.5 if the source is a combustion source. Do not include condensable particulate matter for PM unless PM is set equal to PM10 and PM2.5. Particulate matter (PM) is not subject to an ambient air quality standard, but it is a regulated air pollutant under PSD (20.2.74 NMAC) and Title V (20.2.70 NMAC).

Table 2-G: Stack Exit and Fugitive Emission Rates for Special Stacks

I have elected to leave this table blank because this facility does not have any stacks/vents that split emissions from a single source or combine emissions from more than one source listed in table 2-A. Additionally, the emission rates of all stacks match the Requested allowable emission rates stated in Table 2-E.

Use this table to list stack emissions (requested allowable) from split and combined stacks. List Toxic Air Pollutants (TAPs) and Hazardous Air Pollutants (HAPs) in Table 2-I. List all fugitives that are associated with the normal, routine, and non-emergency operation of the facility. Unit and stack numbering must correspond throughout the application package. Refer to Table 2-E for instructions on use of the “-“ symbol and on significant figures.

Stack No.	Serving Unit Number(s) from Table 2-A	NOx		CO		VOC		SOx		PM		PM10		PM2.5		☐ H ₂ S or ☐ Lead	
		lb/hr	ton/yr	lb/hr	ton/yr	lb/hr	ton/yr	lb/hr	ton/yr	lb/hr	ton/yr	lb/hr	ton/yr	lb/hr	ton/yr	lb/hr	ton/yr
Totals:																	

Table 2-H: Stack Exit Conditions

Unit and stack numbering must correspond throughout the application package. Include the stack exit conditions for each unit that emits from a stack, including blowdown venting parameters and tank emissions. If the facility has multiple operating scenarios, complete a separate Table 2-H for each scenario and, for each, type scenario name here:

Stack Number	Serving Unit Number(s) from Table 2-A	Orientation (H=Horizontal V=Vertical)	Rain Caps (Yes or No)	Height Above Ground (ft)	Temp. (F)	Flow Rate		Moisture by Volume (%)	Velocity (ft/sec)	Inside Diameter (ft)
						(acfs)	(dscfs)			
1	1	V	No	29	440	497			120	2.29
2	2	V	No	29	440	231.70			56.17	2.29
3	3	V	No	29	440	231.70			56.17	2.29

Table 2-I: Stack Exit and Fugitive Emission Rates for HAPs and TAPs

In the table below, report the Potential to Emit for each HAP from each regulated emission unit listed in Table 2-A, only if the entire facility emits the HAP at a rate greater than or equal to one (1) ton per year. For each such emission unit, HAPs shall be reported to the nearest 0.1 tpy. Each facility-wide Individual HAP total and the facility-wide Total HAPs shall be the sum of all HAP sources calculated to the nearest 0.1 ton per year. Per 20.2.72.403.A.1 NMAC, facilities not exempt [see 20.2.72.402.C NMAC] from TAP permitting shall report each TAP that has an uncontrolled emission rate in excess of its pounds per hour screening level specified in 20.2.72.502 NMAC. TAPs shall be reported using one more significant figure than the number of significant figures shown in the pound per hour threshold corresponding to the substance. Use the HAP nomenclature as it appears in Section 112 (b) of the 1990 CAAA and the TAP nomenclature as it listed in 20.2.72.502 NMAC. Include tank-flashing emissions estimates of HAPs in this table. For each HAP or TAP listed, fill all cells in this table with the emission numbers or a "-" symbol. A "-" symbol indicates that emissions of this pollutant are not expected or the pollutant is emitted in a quantity less than the threshold amounts described above.

Stack No.	Unit No.(s)	Total HAPs		Formaldehyde <input checked="" type="checkbox"/> HAP or <input type="checkbox"/> TAP		Hexane <input checked="" type="checkbox"/> HAP or <input type="checkbox"/> TAP		Benzene <input checked="" type="checkbox"/> HAP or <input type="checkbox"/> TAP		Toluene <input checked="" type="checkbox"/> HAP or <input type="checkbox"/> TAP		Provide Pollutant Name Here <input type="checkbox"/> HAP or <input type="checkbox"/> TAP		Provide Pollutant Name Here <input type="checkbox"/> HAP or <input type="checkbox"/> TAP		Provide Pollutant Name Here <input type="checkbox"/> HAP or <input type="checkbox"/> TAP		Provide Pollutant Name Here <input type="checkbox"/> HAP or <input type="checkbox"/> TAP				
		lb/hr	ton/yr	lb/hr	ton/yr	lb/hr	ton/yr	lb/hr	ton/yr	lb/hr	ton/yr	lb/hr	ton/yr	lb/hr	ton/yr	lb/hr	ton/yr	lb/hr	ton/yr	lb/hr	ton/yr	
1	1	35.27	1.48	22.80	0.13	0.079	0.35	9.26E-05	4.06E-04	1.50E-04	6.66E-04											
2	2	11.10	0.665	4.95	0.032	0.037	0.16	4.32E-05	1.90E-04	9.30E-04	3.11E-04											
3	3	11.10	0.665	4.95	0.032	0.037	0.16	4.32E-05	1.90E-04	9.30E-04	3.11E-04											
Totals:		57.48	2.81	32.70	0.19	0.15	0.67	1.79E-04	7.85E-04	0.0020	0.0013											

Table 2-J: Fuel

Specify fuel characteristics and usage. Unit and stack numbering must correspond throughout the application package.

Unit No.	Fuel Type (low sulfur Diesel, ultra low sulfur diesel, Natural Gas, Coal, ...)	Fuel Source: purchased commercial, pipeline quality natural gas, residue gas, raw/field natural gas, process gas (e.g. SRU tail gas) or other	Specify Units				
			Lower Heating Value	Hourly Usage	Annual Usage	% Sulfur	% Ash
1	Natural Gas	Purchased Commercial	1020 Btu/scf	0.044 MMSCF/hr	386 MMSCF/yr		
1	Low Sulfur Diesel	Purchased Commercial	138,500 BTU/gal	304 gal/hr	3040 gal/yr	15 ppm	
2	Natural Gas	Purchased Commercial	1020	0.021 MMSCF/hr	183.96 MMSCF/yr		
2	Low Sulfur Diesel	Purchased Commercial	138,5000 BTU/gal	150 gal/hr	1500 gal/yr	15 ppm	
3	Natural Gas	Purchased Commercial	1020	0.021 MMSCF/hr	183.96 MMSCF/yr		
3	Low Sulfur Diesel	Purchased Commercial	138,5000 BTU/gal	150 gal/hr	1500 gal/yr	15 ppm	

Table 2-K: Liquid Data for Tanks Listed in Table 2-L

For each tank, list the liquid(s) to be stored in each tank. If it is expected that a tank may store a variety of hydrocarbon liquids, enter "mixed hydrocarbons" in the Composition column for that tank and enter the corresponding data of the most volatile liquid to be stored in the tank. If tank is to be used for storage of different materials, list all the materials in the "All Calculations" attachment, run the newest version of TANKS on each, and use the material with the highest emission rate to determine maximum uncontrolled and requested allowable emissions rate. The permit will specify the most volatile category of liquids that may be stored in each tank. Include appropriate tank-flashing modeling input data. Use additional sheets if necessary. Unit and stack numbering must correspond throughout the application package.

Tank No.	SCC Code	Material Name	Composition	Liquid Density (lb/gal)	Vapor Molecular Weight (lb/lb*mol)	Average Storage Conditions		Max Storage Conditions	
						Temperature (°F)	True Vapor Pressure (psia)	Temperature (°F)	True Vapor Pressure (psia)

Table 2-L: Tank Data

Include appropriate tank-flashing modeling input data. Use an addendum to this table for unlisted data categories. Unit and stack numbering must correspond throughout the application package. Use additional sheets if necessary. See reference Table 2-L2. Note: 1.00 bbl = 10.159 M3 = 42.0 gal

Tank No.	Date Installed	Materials Stored	Seal Type (refer to Table 2-LR below)	Roof Type (refer to Table 2-LR below)	Capacity		Diameter (M)	Vapor Space (M)	Color (from Table VI-C)		Paint Condition (from Table VI-C)	Annual Throughput (gal/yr)	Turn-overs (per year)
					(bbl)	(M ³)			Roof	Shell			

Table 2-L2: Liquid Storage Tank Data Codes Reference Table

Roof Type	Seal Type, Welded Tank Seal Type		Seal Type, Riveted Tank Seal Type		Roof, Shell Color	Paint Condition
	Mechanical Shoe Seal	Liquid-mounted resilient seal	Vapor-mounted resilient seal	Seal Type		
FX: Fixed Roof					WH: White	Good
IF: Internal Floating Roof	A: Primary only	A: Primary only	A: Primary only	A: Mechanical shoe, primary only	AS: Aluminum (specular)	Poor
EF: External Floating Roof	B: Shoe-mounted secondary	B: Weather shield	B: Weather shield	B: Shoe-mounted secondary	AD: Aluminum (diffuse)	
P: Pressure	C: Rim-mounted secondary	C: Rim-mounted secondary	C: Rim-mounted secondary	C: Rim-mounted secondary	LG: Light Gray	
					MG: Medium Gray	
					BL: Black	
					OT: Other (specify)	

Note: 1.00 bbl = 0.159 M³ = 42.0 gal

Table 2-M: Materials Processed and Produced (Use additional sheets as necessary.)

Material Processed				Material Produced			
Description	Chemical Composition	Phase (Gas, Liquid, or Solid)	Quantity (specify units)	Description	Chemical Composition	Phase	Quantity (specify units)

Table 2-N: CEM Equipment

Enter Continuous Emissions Measurement (CEM) Data in this table. If CEM data will be used as part of a federally enforceable permit condition, or used to satisfy the requirements of a state or federal regulation, include a copy of the CEM's manufacturer specification sheet in the Information Used to Determine Emissions attachment. Unit and stack numbering must correspond throughout the application package. Use additional sheets if necessary.

Stack No.	Pollutant(s)	Manufacturer	Model No.	Serial No.	Sample Frequency	Averaging Time	Range	Sensitivity	Accuracy

Table 2-O: Parametric Emissions Measurement Equipment

Unit and stack numbering must correspond throughout the application package. Use additional sheets if necessary.

Unit No.	Parameter/Pollutant Measured	Location of Measurement	Unit of Measure	Acceptable Range	Frequency of Maintenance	Nature of Maintenance	Method of Recording	Averaging Time

Table 2-P: Greenhouse Gas Emissions

Applications submitted under 20.2.70, 20.2.72, & 20.2.74 NMAC are required to complete this Table. Power plants, Title V major sources, and PSD major sources must report and calculate all GHG emissions for each unit. Applicants must report potential emission rates in short tons per year (see Section 6.a for assistance). Include GHG emissions during Startup, Shutdown, and Scheduled Maintenance in this table. For minor source facilities that are not power plants, are not Title V, or are not PSD, there are three options for reporting GHGs 1) report GHGs for each individual piece of equipment; 2) report all GHGs from a group of unit types, for example report all combustion source GHGs as a single unit and all venting GHG as a second separate unit; OR 3) check the following box By checking this box, the applicant acknowledges the total CO₂e emissions are less than 75,000 tons per year.

Unit No.	GWPs ¹	CO ₂ ton/yr	N ₂ O ton/yr	CH ₄ ton/yr	SF ₆ ton/yr	PFC/HFC ton/yr ²										Total GHG Mass Basis ton/yr ⁴	Total CO ₂ e ton/yr ⁵
		1	298	25	22,800	footnote 3											
	mass GHG																
	CO ₂ e																
	mass GHG																
	CO ₂ e																
	mass GHG																
	CO ₂ e																
	mass GHG																
	CO ₂ e																
	mass GHG																
	CO ₂ e																
	mass GHG																
	CO ₂ e																
	mass GHG																
	CO ₂ e																
	mass GHG																
	CO ₂ e																
	mass GHG																
	CO ₂ e																
Total	mass GHG																
	CO ₂ e																

¹ GWP (Global Warming Potential): Applicants must use the most current GWPs codified in Table A-1 of 40 CFR part 98. GWPs are subject to change, therefore, applicants need to check 40 CFR 98 to confirm GWP values.

² For HFCs or PFCs describe the specific HFC or PFC compound and use a separate column for each individual compound.

³ For each new compound, enter the appropriate GWP for each HFC or PFC compound from Table A-1 in 40 CFR 98.

⁴ Green house gas emissions on a mass basis is the ton per year green house gas emission before adjustment with its GWP.

⁵ CO₂e means Carbon Dioxide Equivalent and is calculated by multiplying the TPY mass emissions of the green house gas by its GWP.

Section 3

Application Summary

The **Application Summary** shall include a brief description of the facility and its process, the type of permit application, the applicable regulation (i.e. 20.2.72.200.A.X, or 20.2.73 NMAC) under which the application is being submitted, and any air quality permit numbers associated with this site. If this facility is to be collocated with another facility, provide details of the other facility including permit number(s). In case of a revision or modification to a facility, provide the lowest level regulatory citation (i.e. 20.2.72.219.B.1.d NMAC) under which the revision or modification is being requested. Also describe the proposed changes from the original permit, how the proposed modification will affect the facility's operations and emissions, de-bottlenecking impacts, and changes to the facility's major/minor status (both PSD & Title V).

The **Process Summary** shall include a brief description of the facility and its processes.

Startup, Shutdown, and Maintenance (SSM) routine or predictable emissions: Provide an overview of how SSM emissions are accounted for in this application. Refer to "Guidance for Submittal of Startup, Shutdown, Maintenance Emissions in Permit Applications (http://www.env.nm.gov/aqb/permit/app_form.html) for more detailed instructions on SSM emissions.

Facility Description:

Tagawa Greenhouse Enterprises, LLC owns and operates Tagawa Southwest, located in Torrance County. The facility is an enclosed greenhouse. Tagawa Southwest is currently permitted under NSR permit No. 2128-M1-R1. The purpose of this significant revision application is to replace one (1) existing 45 MMBtu/hr boiler (Unit 2) which is no longer operational with two (2) 21 MMBtu/hr units. Equipment to be permitted at the facility is discussed below.

Equipment:

- One (1) Thermeta LN100 45 MMBtu/hr Boiler Unit (1)
- Two (2) 21 MMBtu/hr Boiler Units (2 & 3)
- One (1) 354 HP Emergency Generator (exempt pursuant 20.2.72.202.B.3 NMAC)

Process Equipment:

Tagawa Southwest is equipped with one (1) 45 MMBtu/hr and two (2) 21 MMBtu/hr boiler units. The boiler units are dual fuel units, capable of combusting both natural gas and diesel fuel. For routine operation, the units will use natural gas as a fuel source. In emergency situations, diesel fuel may be used. This application accounts for up to 10 hours/year of emergency diesel fuel usage.

Section 4

Process Flow Sheet

A **process flow sheet** and/or block diagram indicating the individual equipment, all emission points and types of control applied to those points. The unit numbering system should be consistent throughout this application.

A process flow sheet is attached.

Tagawa Greenhouse Enterprises, LLC

Tagawa Southwest

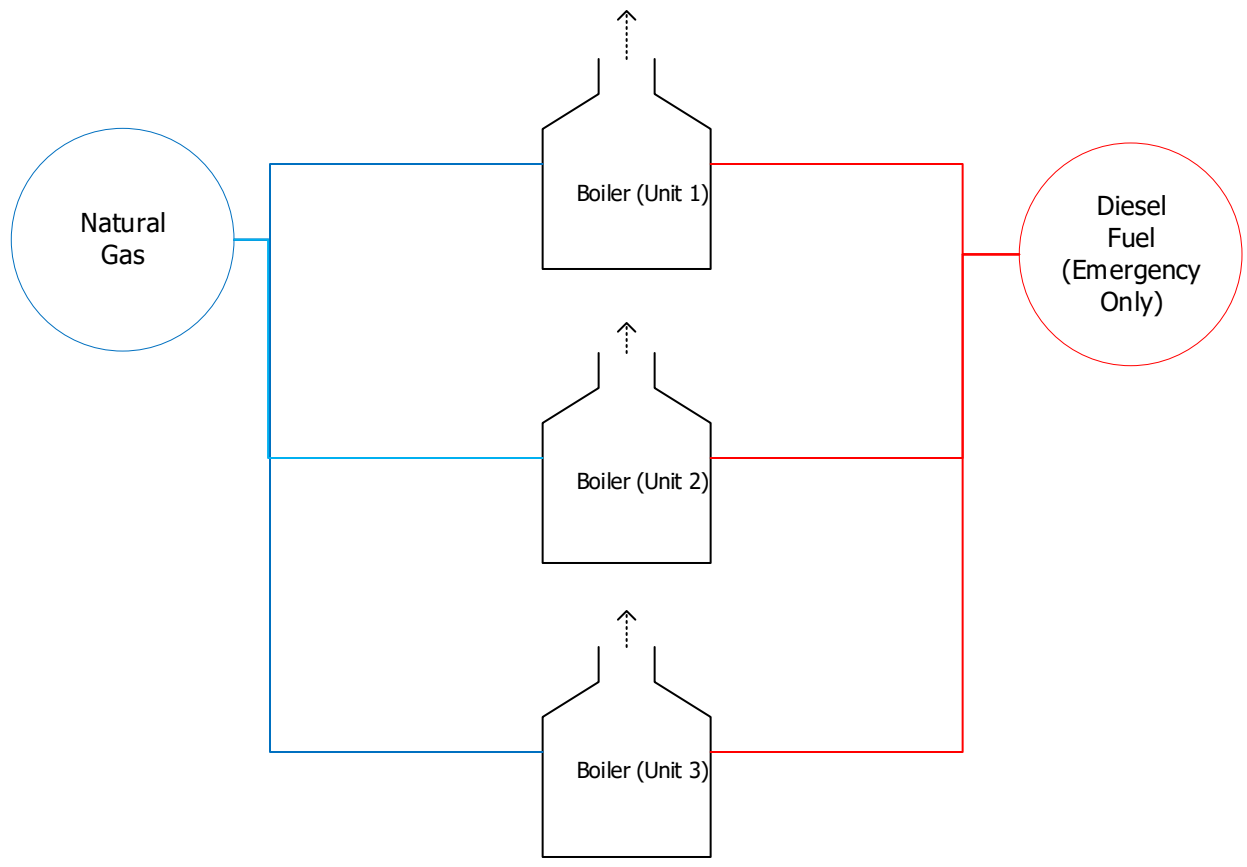

----->
Emissions

Section 5

Plot Plan Drawn To Scale

A **plot plan drawn to scale** showing emissions points, roads, structures, tanks, and fences of property owned, leased, or under direct control of the applicant. This plot plan must clearly designate the restricted area as defined in UA1, Section 1-D.12. The unit numbering system should be consistent throughout this application.

A plot plan has been included in this section.

BOUNDARY SURVEY OF TRACTS A-1 & B-1 FOR TAGAWA GREENHOUSES INC.

EAST 1/2 SECTION 10, T. 05 N., R. 08 E., N.M.P.M.,
TORRANCE COUNTY, NEW MEXICO
CONTAINING 317.737 AC. ±

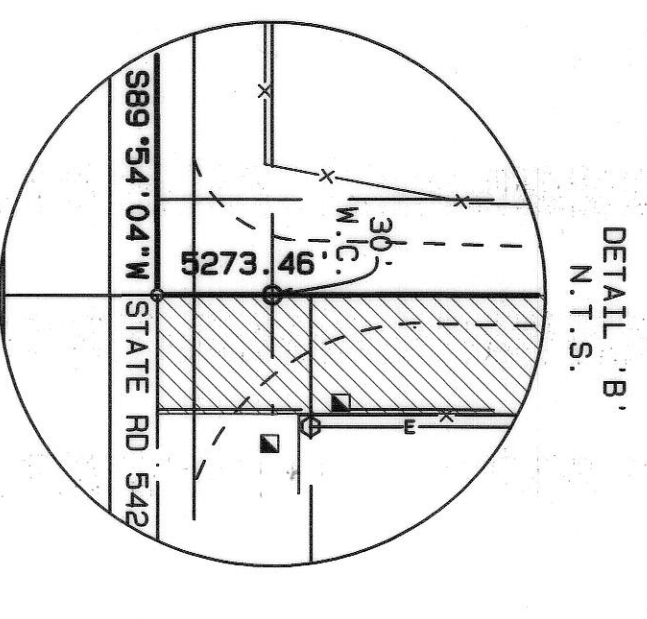
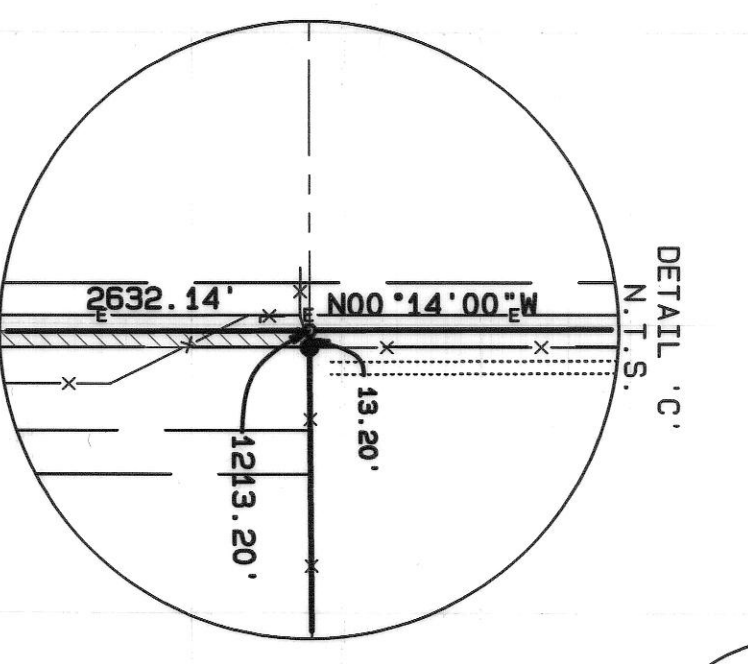
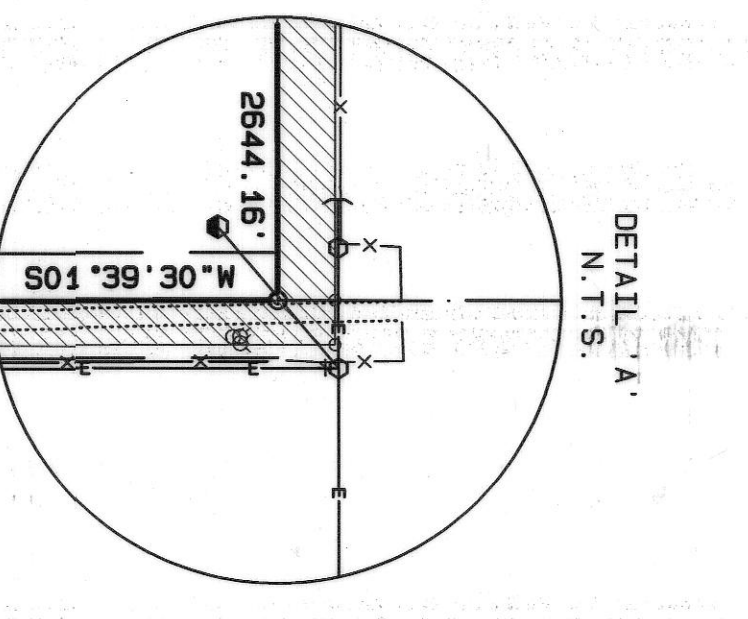
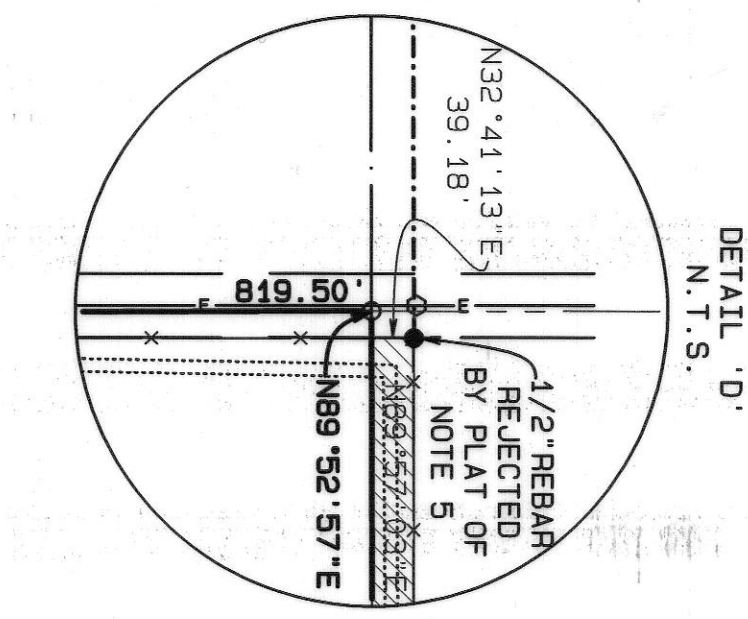
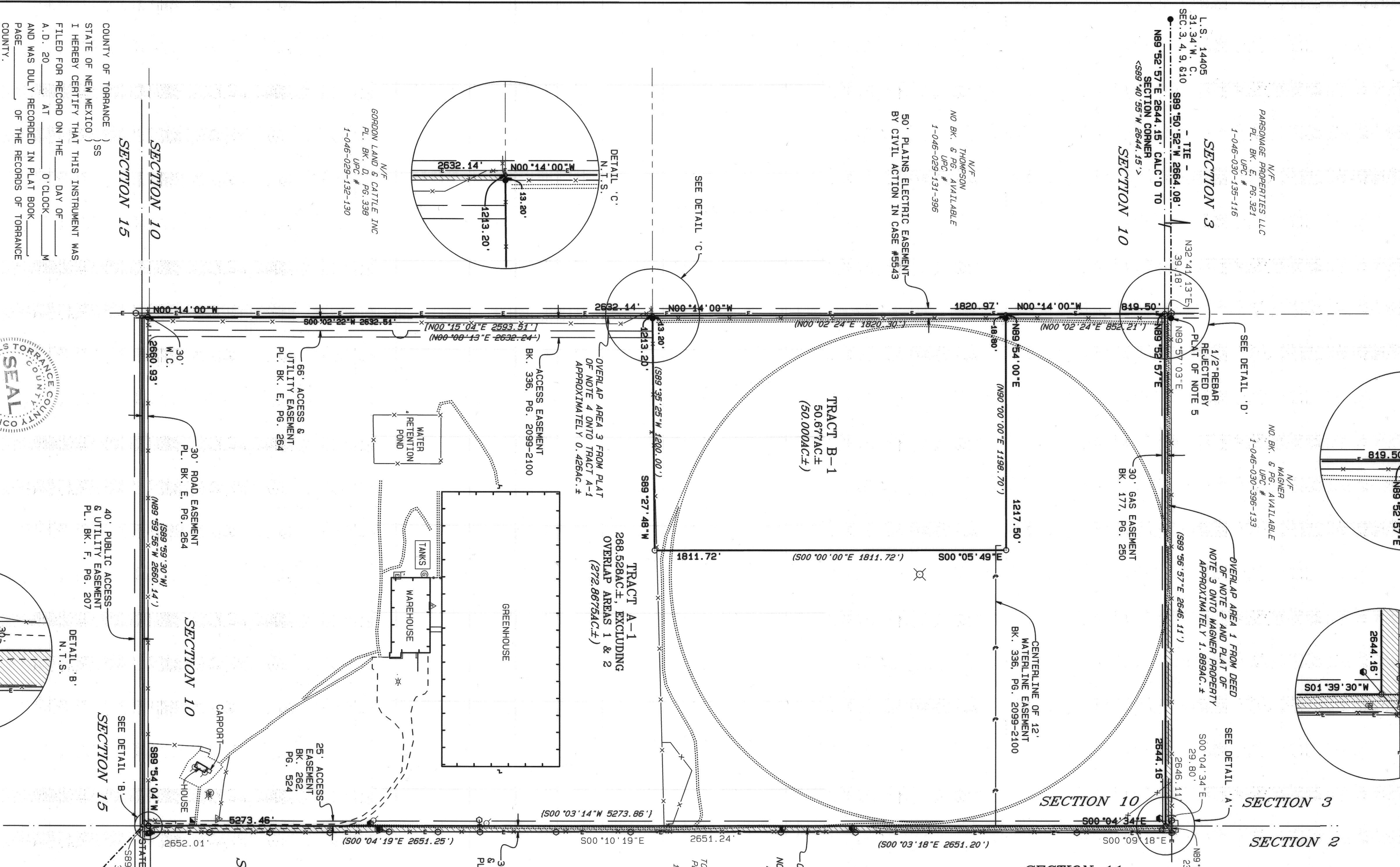
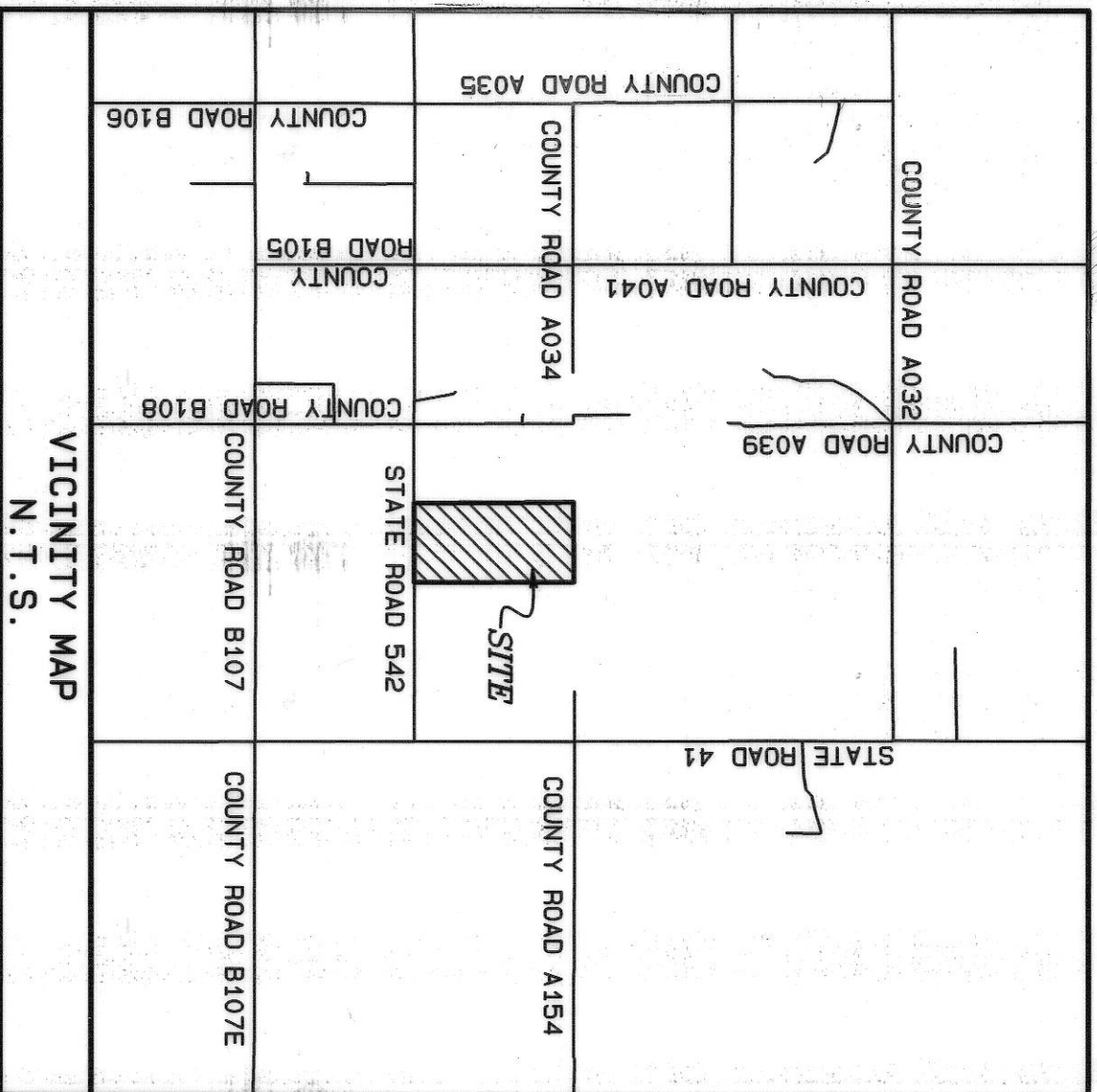

- NOTES:**
- BASIS OF BEARING: POST PROCESSED RTK GNSS OBSERVATION FROM STATE PLANE COORDINATE SYSTEM
 - ZONE: NM CENTRAL
HORIZONTAL DATUM: NAD83
VERTICAL DATUM: GRS 1980
ELEVATION: 6140.86
GROUND TO GRID FACTOR: 0.99961249
 - REFER TO WARRANTY DEED, SUNNYLAND FARMS, INC. TO TAGAWA GREENHOUSES, INC., RECORDED AS INSTRUMENT #2044655 AT THE TORRANCE COUNTY CLERK'S OFFICE. REFER TO SPECIAL WARRANTY DEED, WESTERN WATER AND POWER PRODUCTION LIMITED, LLC TO TAGAWA GREENHOUSES, INC., RECORDED IN BOOK 336, PAGE 2099 AT THE TORRANCE COUNTY CLERK'S OFFICE.
 - REFER TO PLAT ENTITLED "PLAT OF TRACT A-1 AND B-1" PREPARED BY JERRY NICKELS, N.M.P.L.S. NO. 6256, RECORDED IN BOOK E, PAGE 264 ON NOVEMBER 23, 2004 AT THE TORRANCE COUNTY CLERK'S OFFICE. RECORD DATA IN PARENTHESIS ().
 - REFER TO PLAT ENTITLED ".35 ACRES EXEMPTION PLAT OF THE LANDS OF HAROLD JIMMY JONES" PREPARED BY TIMOTHY RAY OREN, N.M.P.L.S. NO. 9667, RECORDED IN BOOK D, PAGE 388 ON JUNE 6, 1999 AT THE TORRANCE COUNTY CLERK'S OFFICE. RECORD DATA IN BRACKETS ().
 - REFER TO PLAT ENTITLED "LAND DIVISION CREATED BY 140 ACRES EXEMPTION OF THE LANDS OF BERSHIRE RENOVABLE LIVING TRUST AND OBERG LIVING TRUST" PREPARED BY TIMOTHY RAY OREN, N.M.P.L.S. NO. 8667, RECORDED IN BOOK 5, PAGE 321 ON JANUARY 31, 2006 AT THE TORRANCE COUNTY CLERK'S OFFICE. RECORD DATA IN ANGLE BRACKETS < > .
 - REFER TO PLAT ENTITLED "LOT LINE ADJUSTMENT AND LOT CONSOLIDATION EXEMPTION PLAT OF THE LANDS OF TOM AND JERRY RANCHES, LLC" PREPARED BY ROGER G. SCUSSELL, N.M.P.L.S. NO. 14405, RECORDED IN BOOK F, PAGE 207 ON JANUARY 11, 2011 AT THE TORRANCE COUNTY CLERK'S OFFICE. RECORD DATA IN BRACES { } .
 - REFER TO PLAT ENTITLED "LAND DIVISION LANDS OF DONALD G. AND CAROL R. ANSLER" PREPARED BY JERRY NICKELS, N.M.P.L.S. NO. 6256, RECORDED IN BOOK 268 ON MARCH 2, 1999 AT THE TORRANCE COUNTY CLERK'S OFFICE. (LOT OF RECORD).
 - REFER TO GRANT OF EASEMENT, JORGE FARMS INC. TO E. M. W. 6AS ASSOCIATION, RECORDED IN BOOK 177, PAGE 250 ON MAY 3, 1968 AT THE TORRANCE COUNTY CLERK'S OFFICE.
 - THESE LANDS LIE WITHIN ZONE "X". AREAS DETERMINED TO BE OUTSIDE THE 0.2% ANNUAL CHANCE FLOODPLAIN, AS PER F.I.R.M. COMMUNITY PANEL NO. 3504330019B, DATED OCTOBER 1, 2011.
 - THIS SURVEY IS TIED TO 31.34' WITNESS CORNER L.S. 14405 FOR SECTIONS 3, 4, 9 & 10 BASED ON SECTION BREAKDOWNS AS PER PLATS OF NOTES 5 AND 6.
 - THIS SURVEY IS SUBJECT TO ALL PERTINENT EASEMENTS, RESTRICTIONS AND COVENANTS, BOTH RECORDED AND UNRECORDED.

- LEGEND:**
- FOUND L.S. 6256, UNLESS OTHERWISE NOTED
 - SET 1/2" REBAR STAMPED M. NOONAN, N.M.P.L.S. NO. 6998
 - CALCULATED POINT, NOT SET
 - BUILDING LINE
 - - - EDGE OF GRAVEL ROAD
 - EDGE OF DIRT ROAD
 - - - FENCE
 - HUGE ABOVE GROUND GAS LINE
 - × LIGHT POLE
 - ELECTRIC BOX
 - △ GAS METER
 - ⊙ WELL
 - ⊙ SPLITOT
 - TELEPHONE JUNCTION BOX
 - POLE BOLLARD
 - UTILITY POLE
 - () ANCHOR WIRE
 - AERIAL ELECTRIC LINE
 - UTILITY POLE W/ ELECTRIC METER
 - △ PIVOT IRRIGATION
 - △ ELECTRIC METER

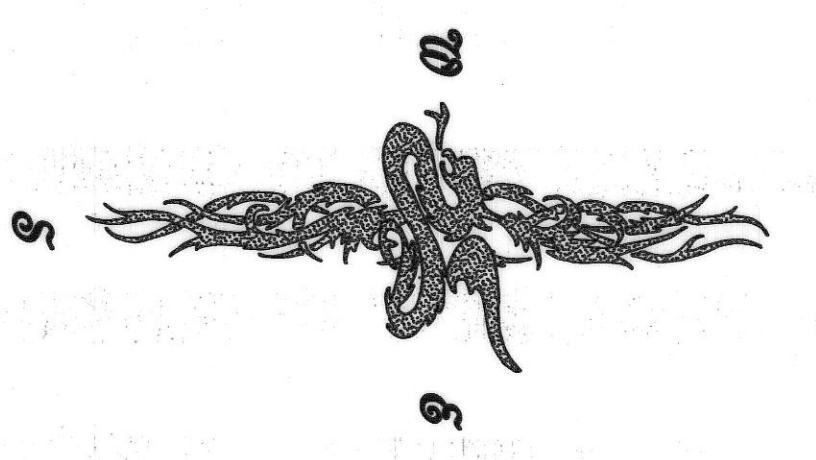
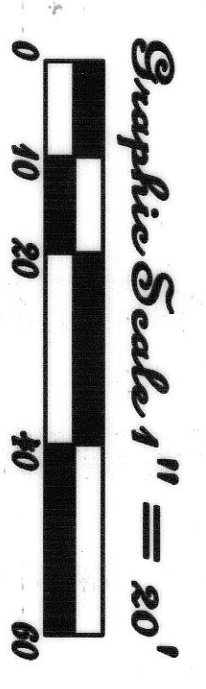

INDEXING INFORMATION FOR COUNTY CLERK

OWNER: TAGAWA GREENHOUSES INC.
 FILED: INST. #2044655
 SUBDIVISION: N/A

1114 HICKOX ST., SANTA FE, N.M. 87501
 (505) 986-9429 FAX (505) 986-3413
 DATE: 05/24/21 DRAWN BY: DWR PROJECT NO: 70-3128

SURVEYOR'S CERTIFICATE

I, MITCHEL K. NOONAN, N.M.P.L.S. NO. 6998 DO HEREBY CERTIFY TO TAGAWA GREENHOUSES INC. THAT THIS BOUNDARY SURVEY PLAY AND THE ACTUAL SURVEY ON THE GROUND UPON WHICH THIS SURVEY WAS BASED WERE HEREBY DIRECTLY SUPERVISED BY ME OR UNDER MY DIRECT SUPERVISION AND THAT I AM A LICENSED SURVEYOR IN NEW MEXICO. AND THAT IT IS TRUE AND CORRECT TO THE BEST OF MY KNOWLEDGE AND BELIEF. I FURTHER CERTIFY THAT THIS SURVEY IS NOT A LAND DIVISION OR SUBDIVISION AS DEFINED IN THE NEW MEXICO SUBDIVISION ACT AND THAT THIS INSTRUMENT IS A BOUNDARY SURVEY PLAY OF AN EXISTING TRACT OR TRACTS.

1/11/21 & 2/21/21

MITCHEL K. NOONAN
 N.M.P.L.S. NO. 6998

COUNTY OF TORRANCE } SS
 STATE OF NEW MEXICO }
 I HEREBY CERTIFY THAT THIS INSTRUMENT WAS FILED FOR RECORD ON THE _____ DAY OF _____ A.D. 20____ AT _____ O'CLOCK _____ M AND WAS DULY RECORDED IN PLAT BOOK _____ PAGE _____ OF THE RECORDS OF TORRANCE COUNTY.

WITNESS MY HAND AND SEAL OF OFFICE
 YVONNE OTERO,
 COUNTY CLERK, TORRANCE COUNTY, N.M.,
 DEPUTY

Section 6

All Calculations

Show all calculations used to determine both the hourly and annual controlled and uncontrolled emission rates. All calculations shall be performed keeping a minimum of three significant figures. Document the source of each emission factor used (if an emission rate is carried forward and not revised, then a statement to that effect is required). If identical units are being permitted and will be subject to the same operating conditions, submit calculations for only one unit and a note specifying what other units to which the calculations apply. All formulas and calculations used to calculate emissions must be submitted. The "Calculations" tab in the UA2 has been provided to allow calculations to be linked to the emissions tables. Add additional "Calc" tabs as needed. If the UA2 or other spread sheets are used, all calculation spread sheet(s) shall be submitted electronically in Microsoft Excel compatible format so that formulas and input values can be checked. Format all spread sheets and calculations such that the reviewer can follow the logic and verify the input values. Define all variables. If calculation spread sheets are not used, provide the original formulas with defined variables. Additionally, provide subsequent formulas showing the input values for each variable in the formula. All calculations, including those calculations are imbedded in the Calc tab of the UA2 portion of the application, the printed Calc tab(s), should be submitted under this section.

Tank Flashing Calculations: The information provided to the AQB shall include a discussion of the method used to estimate tank-flashing emissions, relative thresholds (i.e., NOI, permit, or major source (NSPS, PSD or Title V)), accuracy of the model, the input and output from simulation models and software, all calculations, documentation of any assumptions used, descriptions of sampling methods and conditions, copies of any lab sample analysis. If Hysis is used, all relevant input parameters shall be reported, including separator pressure, gas throughput, and all other relevant parameters necessary for flashing calculation.

SSM Calculations: It is the applicant's responsibility to provide an estimate of SSM emissions or to provide justification for not doing so. In this Section, provide emissions calculations for Startup, Shutdown, and Routine Maintenance (SSM) emissions listed in the Section 2 SSM and/or Section 22 GHG Tables and the rationale for why the others are reported as zero (or left blank in the SSM/GHG Tables). Refer to "Guidance for Submittal of Startup, Shutdown, Maintenance Emissions in Permit Applications (http://www.env.nm.gov/aqb/permit/app_form.html) for more detailed instructions on calculating SSM emissions. If SSM emissions are greater than those reported in the Section 2, Requested Allowables Table, modeling may be required to ensure compliance with the standards whether the application is NSR or Title V. Refer to the Modeling Section of this application for more guidance on modeling requirements.

Glycol Dehydrator Calculations: The information provided to the AQB shall include the manufacturer's maximum design recirculation rate for the glycol pump. If GRI-Glycalc is used, the full input summary report shall be included as well as a copy of the gas analysis that was used.

Road Calculations: Calculate fugitive particulate emissions and enter haul road fugitives in Tables 2-A, 2-D and 2-E for:

1. If you transport raw material, process material and/or product into or out of or within the facility and have PER emissions greater than 0.5 tpy.
2. If you transport raw material, process material and/or product into or out of the facility more frequently than one round trip per day.

Significant Figures:

- A. All emissions standards are deemed to have at least two significant figures, but not more than three significant figures.
- B. At least 5 significant figures shall be retained in all intermediate calculations.
- C. In calculating emissions to determine compliance with an emission standard, the following rounding off procedures shall be used:

- (1) If the first digit to be discarded is less than the number 5, the last digit retained shall not be changed;
- (2) If the first digit discarded is greater than the number 5, or if it is the number 5 followed by at least one digit other than the number zero, the last figure retained shall be increased by one unit; **and**
- (3) If the first digit discarded is exactly the number 5, followed only by zeros, the last digit retained shall be rounded upward if it is an odd number, but no adjustment shall be made if it is an even number.
- (4) The final result of the calculation shall be expressed in the units of the standard.

Control Devices: In accordance with 20.2.72.203.A(3) and (8) NMAC, 20.2.70.300.D(5)(b) and (e) NMAC, and 20.2.73.200.B(7) NMAC, the permittee shall report all control devices and list each pollutant controlled by the control device

regardless if the applicant takes credit for the reduction in emissions. The applicant can indicate in this section of the application if they chose to not take credit for the reduction in emission rates. For notices of intent submitted under 20.2.73 NMAC, only uncontrolled emission rates can be considered to determine applicability unless the state or federal Acts require the control. This information is necessary to determine if federally enforceable conditions are necessary for the control device, and/or if the control device produces its own regulated pollutants or increases emission rates of other pollutants.

Boilers (Units 1, 2, and 3)

Natural Gas Combustion

Emission factors for NO_x and CO are based on AP-42 Table 1.4-1 (July 1998). Because the firing rates of the units are less than 100 MMBtu/hr. the emission factors for small boilers were used. Unit 1 has a low NO_x burner. Emission factors for PM_{2.5}, PM₁₀, and VOC are based on AP-42 Table 1.4-2 (July 1998). All PM (total, condensable, and filterable) is assumed to be less than 1.0 micrometer in diameter, according to AP-42 Table 1.4-2, footnote c. Therefore, the PM/PM₁₀/PM_{2.5} emission factor is the sum of the filterable PM and condensable PM emission factors. SO₂ emissions were calculated based on a fuel sulfur content of 2 grains of sulfur per 100 standard cubic feet. Emission factors for HAPs are based on AP-42 Table 1.4-3 (July 1998).

Diesel Fuel Combustion

Emission factors for NO_x, CO, PM_{2.5}, and PM₁₀ are based on AP-42 Table 1.3-1 (May 2010). Because the firing rates of the units are less than 100 MMBtu/hr the emission factors for small boilers were used. Unit 1 has a low NO_x burner. Emission factors for VOC are based on AP-42 Table 1.3-3 (May 2010), with factors for NMTOC utilized for this application. SO₂ emissions were calculated based on ultra-low diesel sulfur content of 15 ppm. Emission factors for HAPs are based on AP-42 Table 1.3-9 (May 2010).

Since the boilers will only ever combust natural gas or diesel fuel, but not both simultaneously, the hourly emission rates are based on the fuel producing the maximum emissions on a per pollutant basis. Annual emission rates are based on maximum operation equivalent to 8,760 hrs/yr for natural gas and approximately 10 hours for diesel.

Emission Calculation Inputs

Site-Wide		
Description	Value	Unit
Annual Operating Hours	8,760	hr
Daily Operating Hours	24	hr
Site Elevation	6,153	ft MSL
Fuel Heat Value	1,020.0	Btu/scf

Boiler Input Information			
Unit:	1		
Description:	45 MMBtu/hr Boiler		
Heat input:	45	MMBtu/hr	Manufacturer Specified Burner Heat Input
Fuel heat value:	1,020	Btu/scf	Pipeline Quality Natural Gas
Fuel sulfur content:	2	gr/100scf	Estimated for sweet field gas
Diesel Fuel Usage:	304	gal/hr	Manufacturer Specified Fuel Flow Rate
Diesel Fuel Sulfur content:	15	ppm	
Operating hours:	8,760	hours/year	
Natural Gas Fuel Usage:	44117.6	scf/hr	
Unit:	2 & 3		
Description:	21 MMBtu/hr Boilers		
Heat input:	21	MMBtu/hr	Manufacturer Specified Burner Heat Input
Fuel heat value:	1,020	Btu/scf	Pipeline Quality Natural Gas
Fuel sulfur content:	2	gr/100scf	Estimated for sweet field gas
Diesel Fuel Usage:	150	gal/hr	Manufacturer Specified Fuel Flow Rate
Diesel Fuel Sulfur content:	15	ppm	
Operating hours:	8,760	hours/year	
Natural Gas Fuel Usage:	20588.2	scf/hr	

Emissions Summary

Emission Unit: All
 Source Description: Tagawa Greenhouse, Tagawa Southwest - Maximum Uncontrolled and Controlled Emissions

Maximum Uncontrolled Emissions														
Unit	NO _x		CO		VOC		SO _x		PM ₁₀		PM _{2.5}		Total HAP	
	lb/hr	tpy	lb/hr	tpy	lb/hr	tpy	lb/hr	tpy	lb/hr	tpy	lb/hr	tpy	lb/hr	tpy
1 (Natural Gas)	2.21	9.66	3.71	16.23	0.24	1.06	0.25	1.10	0.34	1.47	0.34	1.47	0.298	1.31
1 (Diesel) ¹	3.04	0.015	1.52	0.0076	0.061	0.00030	0.076	0.00038	0.61	0.0030	0.61	0.0030	35.27	0.18
2 (Natural Gas)	2.06	9.02	1.73	7.57	0.11	1.06	0.12	0.52	0.16	0.69	0.16	0.69	0.139	0.61
2 (Diesel) ¹	3.60	0.018	0.75	0.0038	0.030	0.00015	0.038	0.00019	0.30	0.0015	0.30	0.0015	11.10	0.056
3 (Natural Gas)	2.06	9.02	1.73	7.57	0.11	1.06	0.12	0.52	0.16	0.69	0.16	0.69	0.139	0.61
3 (Diesel) ¹	3.60	0.018	0.75	0.0038	0.030	0.00015	0.038	0.00019	0.30	0.0015	0.30	0.0015	11.10	0.056
Totals	10.24	27.75	7.16	31.40	0.47	3.19	0.49	2.14	1.21	2.85	1.21	2.85	57.48	2.81

"*" Indicates that an hourly limit is not appropriate for this operating situation and is not being requested.

"-" Indicates emissions of this pollutant are not expected.

¹ Alternative Fuel is based on 10 hours of operation per year .

Boiler #1 (Natural Gas)

Boiler Input Information			
Unit(s):	1		
Description:	45 MMBtu/hr Boiler		
Heat input:	45.00	MMBtu/hr	Estimated heat input
Fuel heat value:	1,020	Btu/scf	Pipeline Quality Natural Gas
Fuel sulfur content:	2.0	gr S/100scf	Estimated for field gas
Operating hours:	8,760	hours/year	Estimated Annual Operating Hours
Fuel Usage:	44117.6	scf/hr	

Criteria Pollutant Emission Rates per Unit							
	NO _x	CO	VOC	SO ₂ ¹	PM ^a	Units	Notes
Emission Factors	50	84	5.5	-	7.6	lb/MMscf	AP-42 Table 1.4-1 & 2
	50	84	5.5	-	7.6	lb/MMscf	Adjusted EF, per footnote a in Tables 1.4-1 and 1.4-2
Emissions	2.21	3.71	0.24	0.25	0.34	lb/hr ³	
	9.66	16.23	1.06	1.10	1.47	tons/year ⁴	

HAP Emission Rates per Unit								
	Hexane	Benzene	Toluene	HCHO	Other HAPs ⁵	Total HAPs ⁶	Units	Notes
Emission Factors	1.8	2.10E-03	3.40E-03	0.075	4.88	-	lb/MMscf	AP-42 Table 1.4-3
	1.8	2.10E-03	3.40E-03	7.50E-02	4.88	-	lb/MMscf	Adjusted EF, per footnote a in Table 1.4-3
Emissions	0.079	9.26E-05	1.50E-04	3.31E-03	2.15E-01	0.298	lb/hr ³	
	0.348	4.06E-04	6.57E-04	1.45E-02	9.43E-01	1.31	tons/year ⁴	

¹ SO₂ emissions based on fuel sulfur content of 2 gr S/100 scf
 2.0 g S/100 scf * fuel consumption (Scf/hr) * 64 lb SO₂/32 lb S = lb SO₂/hr

² Assumes PM₁₀ = PM_{2.5}

³ lb/hr emissions calculated using the following methods:
 Criteria and HAPs lb/hr = EF (lb/MMscf) * Rating (MMBtu/hr) / Heat value (Btu/scf)

⁴ For all non-HAP calculations, tons/year = lb/hr * Operating hours * 1ton/2000lb

⁵ Sum of all non-specialized HAP in Table 1.4-3

⁶ Total HAP emissions are the sum of all individual HAPs calculated.

Parameters	Value	Unit	Note
Input heat rate	45.00	MMBtu/hr	Estimated
Fuel heat value	1,020	Btu/scf	Estimated, nominal
Fuel rate	44.12	Mscf/hr	Input heat rate / fuel heat value
Annual fuel usage	386.47	MMscf/yr	8760 actual hrs/yr operation

Parameters	Value	Unit	Note
Input heat rate	45.00	MMBtu/hr	
Exhaust temp	440	°F	Engineering Estimate
Stack height	29	ft	Engineering Estimate
Stack diameter	2.29	ft	Engineering Estimate
Exhaust flow (Actual)	29791	acfm	Flow (acfm) = Flow (scfm) * (Stack Temp + 460) / 528 * 29.92 / Site Bar. Pres. / (100% - Moisture%)
Exhaust flow (Actual)	496.51	acfs	Flow (acfs) = Flow (acfm) / 60s/min
Exhaust velocity	120.37	ft/sec	Exhaust flow / stack area
O ₂ F factor	8,710	dscf/MMBtu	Method 9
Moisture	10	%	Nominal
Exhaust flow (Dry)	12525.6	dscfm	Flow (dscfm) = heat input * O ₂ F * [20.9 / (20.9 - O ₂ %)]
O ₂ %	10	%	
Site Elevation	6,153	ft MSL	
Pressure at Elevation	23.83	in Hg	

Boiler #1 (Diesel)

Boiler Input Information			
Unit(s):	1		
Description:	45 MMBtu/hr Boiler		
Heat input:	45.00	MMBtu/hr	Estimated heat input
Fuel heat value:	1,020	Btu/scf	Pipeline Quality Natural Gas
Fuel sulfur content:	15	ppm	Estimated for field gas
Diesel Fuel Usage:	304.0	gal/hr	Manufacturer Specified Fuel Flow Rate
Operating hours:	10	hours/year	Estimated Annual Operating Hours Requiring Alternative Fuel

Criteria Pollutant Emission Rates per Unit							
	NO _x	CO	VOC	SO ₂ ¹	PM ²	Units	Notes
Emission Factors	0.01	0.005	0.0002	2.50E-04	0.002	lb/10 ³ gal	AP-42 Table 1.3-1
Emissions	3.04	1.520	0.061	7.61E-02	0.61	lb/hr ³	
	0.02	0.008	0.00030	3.81E-04	0.0030	tons/year ⁴	

HAP Emission Rates per Unit								
	Hexane	Benzene	Toluene	HCHO	Other HAPs ⁵	Total HAPs ⁶	Units	Notes
Emission Factors	0	2.14E-07	6.20E-06	0.075	4.10E-02	-	lb/10 ³ gal	AP-42 Table 1.3-9
Emissions	0.00E+00	6.51E-05	1.88E-03	22.80	12.47	35.27	lb/hr ³	
	0.00E+00	3.25E-07	9.42E-06	0.11	0.062	0.18	tons/year ⁴	

¹ SO₂ emissions based on fuel sulfur content of 15 ppm
 15 (ppm=mg/L) * 1lb/gal/119826 mg/L*64 lb SO₂/32 lb S = lb SO₂/hr

² Assumes PM₁₀ = PM_{2.5}

³ lb/hr emissions calculated using the following methods:
 Criteria and HAPs lb/hr = EF (lb/MMscf) * Rating (MMBtu/hr) / Heat value (Btu/scf)

⁴ For all non-HAP calculations, tons/year = lb/hr * Operating hours * 1ton/2000lb

⁵ Sum of all non-specialized HAP in Table 1.4-3

⁶ Total HAP emissions are the sum of all individual HAPs calculated.

Parameters	Value	Unit	Note
Input heat rate	45.00	MMBtu/hr	
Exhaust temp	440	°F	Engineering Estimate
Stack height	29	ft	Engineering Estimate
Stack diameter	2.29	ft	Engineering Estimate
Exhaust flow (Actual)	29791	acfm	Flow (acfm) = Flow (scfm) * (Stack Temp + 460) / 528 * 29.92 / Site Bar. Pres. / (100% - Moisture%)
Exhaust flow (Actual)	496.51	acfs	Flow (acfs) = Flow (acfm) / 60s/min
Exhaust velocity	120.37	ft/sec	Exhaust flow / stack area
O ₂ F factor	8,710	dscf/MMBtu	Method 9
Moisture	10	%	Nominal
Exhaust flow (Dry)	12525.6	dscfm	Flow (dscfm) = heat input * O ₂ F * [20.9 / (20.9 - O ₂ %)]
O ₂ %	10	%	
Site Elevation	6,153	ft MSL	
Pressure at Elevation	23.83	in Hg	

Tagawa Greenhouse, Tagawa Southwest
Boiler #2 & #3 (Natural Gas)

Boiler Input Information			
Unit(s):	2 & 3		
Description:	21 MMBtu/hr Boilers		
Heat input:	21.00	MMBtu/hr	Estimated heat input
Fuel heat value:	1,020	Btu/scf	Pipeline Quality Natural Gas
Fuel sulfur content:	2.0	gr S/100scf	Estimated for field gas
Operating hours:	8,760	hours/year	Estimated Annual Operating Hours
Fuel Usage:	20588.2	scf/hr	

Criteria Pollutant Emission Rates per Unit							
	NO _x	CO	VOC	SO ₂ ¹	PM ²	Units	Notes
Emission Factors	100	84	5.5	-	7.6	lb/MMscf	AP-42 Table 1.4-1 & 2
	100	84	5.5	-	7.6	lb/MMscf	Adjusted EF, per footnote a in Tables 1.4-1 and 1.4-2
Emissions	2.06	1.729	0.1132	1.18E-01	0.16	lb/hr ³	
	9.02	7.57	0.50	5.15E-01	0.69	tons/year ⁴	

HAP Emission Rates per Unit								
	Hexane	Benzene	Toluene	HCHO	Other HAPS ⁵	Total HAPS ⁶	Units	Notes
Emission Factors	1.8	2.10E-03	3.40E-03	0.075	4.88	-	lb/MMscf	AP-42 Table 1.4-3
	1.8	2.10E-03	3.40E-03	7.50E-02	4.88	-	lb/MMscf	Adjusted EF, per footnote a in Table 1.4-3
Emissions	3.71E-02	4.32E-05	7.00E-05	1.54E-03	0.10	0.14	lb/hr ³	
	1.62E-01	1.89E-04	3.07E-04	6.76E-03	0.44	0.61	tons/year ⁴	

- ¹ SO₂ emissions based on fuel sulfur content of 2 gr S/100 scf
² Assumes PM₁₀ = PM_{2.5}
³ lb/hr emissions calculated using the following methods:
Criteria and HAPs lb/hr = EF (lb/MMscf) * Rating (MMBtu/hr) / Heat value (Btu/scf)
⁴ For all non-HAP calculations, tons/year = lb/hr * Operating hours * 1ton/2000lb
⁵ Sum of all non-specialized HAP in Table 1.4-3
⁶ Total HAP emissions are the sum of all individual HAPs calculated.

Parameters	Value	Unit	Note
Input heat rate	21.00	MMBtu/hr	Estimated
Fuel heat value	1,020	Btu/scf	Estimated, nominal
Fuel rate	20.59	Mscf/hr	Input heat rate / fuel heat value
Annual fuel usage	180.35	MMscf/yr	8760 actual hrs/yr operation

Parameters	Value	Unit	Note
Input heat rate	21.00	MMBtu/hr	
Exhaust temp	440	°F	Engineering Estimate
Stack height	29	ft	Engineering Estimate
Stack diameter	2.29	ft	Engineering Estimate
Exhaust flow (Actual)	13902	acfm	Flow (acfm) = Flow (scfm) * (Stack Temp + 460) / 528 * 29.92 / Site Bar. Pres. / (100% - Moisture%)
Exhaust flow (Actual)	231.70	acfs	Flow (acfs) = Flow (acfm) / 60s/min
Exhaust velocity	56.17	ft/sec	Exhaust flow / stack area
O ₂ F factor	8,710	dscf/MMBtu	Method 9
Moisture	10	%	Nominal
Exhaust flow (Dry)	5845.3	dscfm	Flow (dscfm) = heat input * O ₂ F * [20.9 / (20.9 - O ₂ %)]
O ₂ %	10	%	
Site Elevation	6,153	ft MSL	
Pressure at Elevation	23.83	in Hg	

Boiler #2 & #3 (Diesel)

Boiler Input Information			
Unit(s):	2 & 3		
Description:	21 MMBtu/hr Boilers		
Heat input:	21.00	MMBtu/hr	Estimated heat input
Fuel heat value:	1,020	Btu/scf	Pipeline Quality Natural Gas
Fuel sulfur content:	15	ppm	Estimated for field gas
Diesel Fuel Usage:	150.0	gal/hr	Manufacturer Specified Fuel Flow Rate
Operating hours:	10	hours/year	Estimated Annual Operating Hours Requiring Alternative Fuel

Criteria Pollutant Emission Rates per Unit							
	NO _x	CO	VOC	SO ₂ ¹	PM ²	Units	Notes
Emission Factors	0.024	0.005	0.0002	2.50E-04	0.002	lb/10 ³ gal	AP-42 Table 1.3-1
Emissions	3.60	0.75	0.030	3.76E-02	0.30	lb/hr ³	
	0.018	0.0038	0.00015	1.88E-04	0.0015	tons/year ⁴	

HAP Emission Rates per Unit								
	Hexane	Benzene	Toluene	HCHO	Other HAPS ⁵	Total HAPS ⁶	Units	Notes
Emission Factors		2.14E-07	6.20E-06	3.30E-02	4.10E-02	-	lb/10 ³ gal	AP-42 Table 1.3-9
Emissions	0.00E+00	3.21E-05	9.30E-04	4.95E+00	6.15	11.10	lb/hr ³	
	0.00E+00	1.61E-07	4.65E-06	2.48E-02	0.031	0.056	tons/year ⁴	

- ¹ SO₂ emissions based on fuel sulfur content of 15 ppm
15 (ppm=mg/L) *1lb/gal/119826 mg/L*64 lb SO₂/32 lb S = lb SO₂/hr
- ² Assumes PM₁₀ = PM_{2.5}
- ³ lb/hr emissions calculated using the following methods:
Criteria and HAPs lb/hr = EF (lb/MMscf) * Rating (MMBtu/hr) / Heat value (Btu/scf)
- ⁴ For all non-HAP calculations, tons/year = lb/hr * Operating hours * 1ton/2000lb
- ⁵ Sum of all non-specialized HAP in Table 1.4-3
- ⁶ Total HAP emissions are the sum of all individual HAPs calculated.

Parameters	Value	Unit	Note
Input heat rate	21.00	MMBtu/hr	
Exhaust temp	440	°F	Engineering Estimate
Stack height	29	ft	Engineering Estimate
Stack diameter	2.29	ft	Engineering Estimate
Exhaust flow (Actual)	13902	acfm	Flow (acfm) = Flow (scfm) * (Stack Temp + 460) / 528 * 29.92 / Site Bar. Pres. / (100% - Moisture%)
Exhaust flow (Actual)	231.70	acfs	Flow (acfs) = Flow (acfm) / 60s/min
Exhaust velocity	56.17	ft/sec	Exhaust flow / stack area
O ₂ F factor	8,710	dscf/MMBtu	Method 9
Moisture	10	%	Nominal
Exhaust flow (Dry)	5845.3	dscfm	Flow (dscfm) = heat input * O ₂ F * [20.9 / (20.9 - O ₂ %)]
O ₂ %	10	%	
Site Elevation	6,153	ft MSL	
Pressure at Elevation	23.83	in Hg	

Section 6.a

Green House Gas Emissions

(Submitting under 20.2.70, 20.2.72 20.2.74 NMAC)

Title V (20.2.70 NMAC), Minor NSR (20.2.72 NMAC), and PSD (20.2.74 NMAC) applicants must estimate and report greenhouse gas (GHG) emissions to verify the emission rates reported in the public notice, determine applicability to 40 CFR 60 Subparts, and to evaluate Prevention of Significant Deterioration (PSD) applicability. GHG emissions that are subject to air permit regulations consist of the sum of an aggregate group of these six greenhouse gases: carbon dioxide (CO₂), nitrous oxide (N₂O), methane (CH₄), hydrofluorocarbons (HFCs), perfluorocarbons (PFCs), and sulfur hexafluoride (SF₆).

Calculating GHG Emissions:

1. Calculate the ton per year (tpy) GHG mass emissions and GHG CO₂e emissions from your facility.
2. GHG mass emissions are the sum of the total annual tons of greenhouse gases without adjusting with the global warming potentials (GWPs). GHG CO₂e emissions are the sum of the mass emissions of each individual GHG multiplied by its GWP found in Table A-1 in 40 CFR 98 Mandatory Greenhouse Gas Reporting.
3. Emissions from routine or predictable start up, shut down, and maintenance must be included.
4. Report GHG mass and GHG CO₂e emissions in Table 2-P of this application. Emissions are reported in **short** tons per year and represent each emission unit's Potential to Emit (PTE).
5. All Title V major sources, PSD major sources, and all power plants, whether major or not, must calculate and report GHG mass and CO₂e emissions for each unit in Table 2-P.
6. For minor source facilities that are not power plants, are not Title V, and are not PSD there are three options for reporting GHGs in Table 2-P: 1) report GHGs for each individual piece of equipment; 2) report all GHGs from a group of unit types, for example report all combustion source GHGs as a single unit and all venting GHGs as a second separate unit; 3) or check the following By checking this box, the applicant acknowledges the total CO₂e emissions are less than 75,000 tons per year.

Sources for Calculating GHG Emissions:

- Manufacturer's Data
- AP-42 Compilation of Air Pollutant Emission Factors at <http://www.epa.gov/ttn/chief/ap42/index.html>
- EPA's Internet emission factor database WebFIRE at <http://cfpub.epa.gov/webfire/>
- 40 CFR 98 Mandatory Green House Gas Reporting except that tons should be reported in short tons rather than in metric tons for the purpose of PSD applicability.
- API Compendium of Greenhouse Gas Emissions Methodologies for the Oil and Natural Gas Industry. August 2009 or most recent version.
- Sources listed on EPA's NSR Resources for Estimating GHG Emissions at <http://www.epa.gov/nsr/clean-air-act-permitting-greenhouse-gases>:

Global Warming Potentials (GWP):

Applicants must use the Global Warming Potentials codified in Table A-1 of the most recent version of 40 CFR 98 Mandatory Greenhouse Gas Reporting. The GWP for a particular GHG is the ratio of heat trapped by one unit mass of the GHG to that of one unit mass of CO₂ over a specified time period.

"Greenhouse gas" for the purpose of air permit regulations is defined as the aggregate group of the following six gases: carbon dioxide, nitrous oxide, methane, hydrofluorocarbons, perfluorocarbons, and sulfur hexafluoride. **(20.2.70.7 NMAC, 20.2.74.7 NMAC)**. You may also find GHGs defined in 40 CFR 86.1818-12(a).

Metric to Short Ton Conversion:

Short tons for GHGs and other regulated pollutants are the standard unit of measure for PSD and title V permitting programs. 40 CFR 98 Mandatory Greenhouse Reporting requires metric tons.

1 metric ton = 1.10231 short tons (per Table A-2 to Subpart A of Part 98 – Units of Measure Conversions)

Section 7

Information Used To Determine Emissions

Information Used to Determine Emissions shall include the following:

- If manufacturer data are used, include specifications for emissions units and control equipment, including control efficiencies specifications and sufficient engineering data for verification of control equipment operation, including design drawings, test reports, and design parameters that affect normal operation.
 - If test data are used, include a copy of the complete test report. If the test data are for an emissions unit other than the one being permitted, the emission units must be identical. Test data may not be used if any difference in operating conditions of the unit being permitted and the unit represented in the test report significantly effect emission rates.
 - If the most current copy of AP-42 is used, reference the section and date located at the bottom of the page. Include a copy of the page containing the emissions factors, and clearly mark the factors used in the calculations.
 - If an older version of AP-42 is used, include a complete copy of the section.
 - If an EPA document or other material is referenced, include a complete copy.
 - Fuel specifications sheet.
 - If computer models are used to estimate emissions, include an input summary (if available) and a detailed report, and a disk containing the input file(s) used to run the model. For tank-flashing emissions, include a discussion of the method used to estimate tank-flashing emissions, relative thresholds (i.e., permit or major source (NSPS, PSD or Title V)), accuracy of the model, the input and output from simulation models and software, all calculations, documentation of any assumptions used, descriptions of sampling methods and conditions, copies of any lab sample analysis.
-

Boiler (Units 1, 2, and 3)

- AP-42 Section 1.4 Tables 1.4-1, 1.4-2, and 1.4-3
- AP-42 Section 1.3 Tables 1.3-1 and 1.3-9

Table 1.3-1. CRITERIA POLLUTANT EMISSION FACTORS FOR FUEL OIL COMBUSTION^a

Firing Configuration (SCC) ^a	SO ₂ ^b		SO ₃ ^c		NO _x ^d		CO ^e		Filterable PM ^f	
	Emission Factor (lb/10 ³ gal)	EMISSION FACTOR RATING	Emission Factor (lb/10 ³ gal)	EMISSION FACTOR RATING	Emission Factor (lb/10 ³ gal)	EMISSION N FACTOR RATING	Emission Factor (lb/10 ³ gal)	EMISSION FACTOR RATING	Emission Factor (lb/10 ³ gal)	EMISSION FACTOR RATING
Boilers > 100 Million Btu/hr										
No. 6 oil fired, normal firing (1-01-004-01), (1-02-004-01), (1-03-004-01)	157S	A	5.7S	C	47	A	5	A	9.19(S)+3.22	A
No. 6 oil fired, normal firing, low NO _x burner (1-01-004-01), (1-02-004-01)	157S	A	5.7S	C	40	B	5	A	9.19(S)+3.22	A
No. 6 oil fired, tangential firing, (1-01-004-04)	157S	A	5.7S	C	32	A	5	A	9.19(S)+3.22	A
No. 6 oil fired, tangential firing, low NO _x burner (1-01-004-04)	157S	A	5.7S	C	26	E	5	A	9.19(S)+3.22	A
No. 5 oil fired, normal firing (1-01-004-05), (1-02-004-04)	157S	A	5.7S	C	47	B	5	A	10	B
No. 5 oil fired, tangential firing (1-01-004-06)	157S	A	5.7S	C	32	B	5	A	10	B
No. 4 oil fired, normal firing (1-01-005-04), (1-02-005-04)	150S	A	5.7S	C	47	B	5	A	7	B
No. 4 oil fired, tangential firing (1-01-005-05)	150S	A	5.7S	C	32	B	5	A	7	B
No. 2 oil fired (1-01-005-01), (1-02-005-01), (1-03-005-01)	142S ^h	A	5.7S	C	24	D	5	A	2	A
No.2 oil fired, LNB/FGR, (1-01-005-01), (1-02-005-01), (1-03-005-01)	142S ^h	A	5.7S	A	10	D	5	A	2	A

Table 1.3-1. (cont.)

Firing Configuration (SCC) ^a	SO ₂ ^b		SO ₃ ^c		NO _x ^d		CO ^e		Filterable PM ^f	
	Emission Factor (lb/10 ³ gal)	EMISSION FACTOR RATING	Emission Factor (lb/10 ³ gal)	EMISSION FACTOR RATING	Emission Factor (lb/10 ³ gal)	EMISSION FACTOR RATING	Emission Factor (lb/10 ³ gal)	EMISSION FACTOR RATING	Emission Factor (lb/10 ³ gal)	EMISSION FACTOR RATING
Boilers < 100 Million Btu/hr										
No. 6 oil fired (1-02-004-02/03) (1-03-004-02/03)	157S	A	2S	A	55	A	5	A	9.19(S)+3.22 ⁱ	B
No. 5 oil fired (1-03-004-04)	157S	A	2S	A	55	A	5	A	10 ⁱ	A
No. 4 oil fired (1-03-005-04)	150S	A	2S	A	20	A	5	A	7	B
Distillate oil fired (1-02-005-02/03) (1-03-005-02/03)	142S	A	2S	A	20	A	5	A	2	A
Residential furnace (A2104004/A2104011)	142S	A	2S	A	18	A	5	A	0.4 ^g	B

- a To convert from lb/103 gal to kg/103 L, multiply by 0.120. SCC = Source Classification Code.
- b References 1-2,6-9,14,56-60. S indicates that the weight % of sulfur in the oil should be multiplied by the value given. For example, if the fuel is 1% sulfur, then S = 1.
- c References 1-2,6-8,16,57-60. S indicates that the weight % of sulfur in the oil should be multiplied by the value given. For example, if the fuel is 1% sulfur, then S = 1.
- d References 6-7,15,19,22,56-62. Expressed as NO₂. Test results indicate that at least 95% by weight of NO_x is NO for all boiler types except residential furnaces, where about 75% is NO. For utility vertical fired boilers use 105 lb/103 gal at full load and normal (>15%) excess air. Nitrogen oxides emissions from residual oil combustion in industrial and commercial boilers are related to fuel nitrogen content, estimated by the following empirical relationship: lb NO₂ /103 gal = 20.54 + 104.39(N), where N is the weight % of nitrogen in the oil. For example, if the fuel is 1% nitrogen, then N = 1.
- e References 6-8,14,17-19,56-61. CO emissions may increase by factors of 10 to 100 if the unit is improperly operated or not well maintained.
- f References 6-8,10,13-15,56-60,62-63. Filterable PM is that particulate collected on or prior to the filter of an EPA Method 5 (or equivalent) sampling train. Particulate emission factors for residual oil combustion are, on average, a function of fuel oil sulfur content where S is the weight % of sulfur in oil. For example, if fuel oil is 1% sulfur, then S = 1.
- g Based on data from new burner designs. Pre-1970's burner designs may emit filterable PM as high as 3.0 lb/103 gal.
- h The SO₂ emission factor for both no. 2 oil fired and for no. 2 oil fired with LNB/FGR, is 142S, not 157S. Errata dated April 28, 2000. Section corrected May 2010.
- i The PM factors for No.6 and No. 5 fuel were reversed. Errata dated April 28, 2000. Section corrected May 2010.

Table 1.3-9. EMISSION FACTORS FOR SPECIATED ORGANIC COMPOUNDS
FROM FUEL OIL COMBUSTION^a

Organic Compound	Average Emission Factor ^b (lb/10 ³ Gal)	EMISSION FACTOR RATING
Benzene	2.14E-04	C
Ethylbenzene	6.36E-05 ^c	E
Formaldehyde ^d	3.30E-02	C
Naphthalene	1.13E-03	C
1,1,1-Trichloroethane	2.36E-04 ^c	E
Toluene	6.20E-03	D
o-Xylene	1.09E-04 ^c	E
Acenaphthene	2.11E-05	C
Acenaphthylene	2.53E-07	D
Anthracene	1.22E-06	C
Benz(a)anthracene	4.01E-06	C
Benzo(b,k)fluoranthene	1.48E-06	C
Benzo(g,h,i)perylene	2.26E-06	C
Chrysene	2.38E-06	C
Dibenzo(a,h) anthracene	1.67E-06	D
Fluoranthene	4.84E-06	C
Fluorene	4.47E-06	C
Indo(1,2,3-cd)pyrene	2.14E-06	C
Phenanthrene	1.05E-05	C
Pyrene	4.25E-06	C
OCDD	3.10E-09 ^c	E

^a Data are for residual oil fired boilers, Source Classification Codes (SCCs) 1-01-004-01/04.

^b References 64-72. To convert from lb/10³ gal to kg/10³ L, multiply by 0.12.

^c Based on data from one source test (Reference 67).

^d The formaldehyde number presented here is based only on data from utilities using No. 6 oil. The number presented in Table 1.3-7 is based on utility, commercial, and industrial boilers.

Table 1.4-1. EMISSION FACTORS FOR NITROGEN OXIDES (NO_x) AND CARBON MONOXIDE (CO) FROM NATURAL GAS COMBUSTION^a

Combustor Type (MMBtu/hr Heat Input) [SCC]	NO _x ^b		CO	
	Emission Factor (lb/10 ⁶ scf)	Emission Factor Rating	Emission Factor (lb/10 ⁶ scf)	Emission Factor Rating
Large Wall-Fired Boilers (>100) [1-01-006-01, 1-02-006-01, 1-03-006-01]				
Uncontrolled (Pre-NSPS) ^c	280	A	84	B
Uncontrolled (Post-NSPS) ^c	190	A	84	B
Controlled - Low NO _x burners	140	A	84	B
Controlled - Flue gas recirculation	100	D	84	B
Small Boilers (<100) [1-01-006-02, 1-02-006-02, 1-03-006-02, 1-03-006-03]				
Uncontrolled	100	B	84	B
Controlled - Low NO _x burners	50	D	84	B
Controlled - Low NO _x burners/Flue gas recirculation	32	C	84	B
Tangential-Fired Boilers (All Sizes) [1-01-006-04]				
Uncontrolled	170	A	24	C
Controlled - Flue gas recirculation	76	D	98	D
Residential Furnaces (<0.3) [No SCC]				
Uncontrolled	94	B	40	B

^a Reference 11. Units are in pounds of pollutant per million standard cubic feet of natural gas fired. To convert from lb/10⁶ scf to kg/10⁶ m³, multiply by 16. Emission factors are based on an average natural gas higher heating value of 1,020 Btu/scf. To convert from lb/10⁶ scf to lb/MMBtu, divide by 1,020. The emission factors in this table may be converted to other natural gas heating values by multiplying the given emission factor by the ratio of the specified heating value to this average heating value. SCC = Source Classification Code. ND = no data. NA = not applicable.

^b Expressed as NO₂. For large and small wall fired boilers with SNCR control, apply a 24 percent reduction to the appropriate NO_x emission factor. For tangential-fired boilers with SNCR control, apply a 13 percent reduction to the appropriate NO_x emission factor.

^c NSPS=New Source Performance Standard as defined in 40 CFR 60 Subparts D and Db. Post-NSPS units are boilers with greater than 250 MMBtu/hr of heat input that commenced construction modification, or reconstruction after August 17, 1971, and units with heat input capacities between 100 and 250 MMBtu/hr that commenced construction modification, or reconstruction after June 19, 1984.

TABLE 1.4-2. EMISSION FACTORS FOR CRITERIA POLLUTANTS AND GREENHOUSE GASES FROM NATURAL GAS COMBUSTION^a

Pollutant	Emission Factor (lb/10 ⁶ scf)	Emission Factor Rating
CO ₂ ^b	120,000	A
Lead	0.0005	D
N ₂ O (Uncontrolled)	2.2	E
N ₂ O (Controlled-low-NO _x burner)	0.64	E
PM (Total) ^c	7.6	D
PM (Condensable) ^c	5.7	D
PM (Filterable) ^c	1.9	B
SO ₂ ^d	0.6	A
TOC	11	B
Methane	2.3	B
VOC	5.5	C

^a Reference 11. Units are in pounds of pollutant per million standard cubic feet of natural gas fired. Data are for all natural gas combustion sources. To convert from lb/10⁶ scf to kg/10⁶ m³, multiply by 16. To convert from lb/10⁶ scf to lb/MMBtu, divide by 1,020. The emission factors in this table may be converted to other natural gas heating values by multiplying the given emission factor by the ratio of the specified heating value to this average heating value. TOC = Total Organic Compounds. VOC = Volatile Organic Compounds.

^b Based on approximately 100% conversion of fuel carbon to CO₂. CO₂[lb/10⁶ scf] = (3.67) (CON) (C)(D), where CON = fractional conversion of fuel carbon to CO₂, C = carbon content of fuel by weight (0.76), and D = density of fuel, 4.2x10⁻⁴ lb/10⁶ scf.

^c All PM (total, condensable, and filterable) is assumed to be less than 1.0 micrometer in diameter. Therefore, the PM emission factors presented here may be used to estimate PM₁₀, PM_{2.5} or PM₁ emissions. Total PM is the sum of the filterable PM and condensable PM. Condensable PM is the particulate matter collected using EPA Method 202 (or equivalent). Filterable PM is the particulate matter collected on, or prior to, the filter of an EPA Method 5 (or equivalent) sampling train.

^d Based on 100% conversion of fuel sulfur to SO₂. Assumes sulfur content is natural gas of 2,000 grains/10⁶ scf. The SO₂ emission factor in this table can be converted to other natural gas sulfur contents by multiplying the SO₂ emission factor by the ratio of the site-specific sulfur content (grains/10⁶ scf) to 2,000 grains/10⁶ scf.

TABLE 1.4-3. EMISSION FACTORS FOR SPECIATED ORGANIC COMPOUNDS FROM NATURAL GAS COMBUSTION^a

CAS No.	Pollutant	Emission Factor (lb/10 ⁶ scf)	Emission Factor Rating
91-57-6	2-Methylnaphthalene ^{b, c}	2.4E-05	D
56-49-5	3-Methylcholanthrene ^{b, c}	<1.8E-06	E
	7,12-Dimethylbenz(a)anthracene ^{b, c}	<1.6E-05	E
83-32-9	Acenaphthene ^{b, c}	<1.8E-06	E
203-96-8	Acenaphthylene ^{b, c}	<1.8E-06	E
120-12-7	Anthracene ^{b, c}	<2.4E-06	E
56-55-3	Benz(a)anthracene ^{b, c}	<1.8E-06	E
71-43-2	Benzene ^b	2.1E-03	B
50-32-8	Benzo(a)pyrene ^{b, c}	<1.2E-06	E
205-99-2	Benzo(b)fluoranthene ^{b, c}	<1.8E-06	E
191-24-2	Benzo(g,h,i)perylene ^{b, c}	<1.2E-06	E
207-08-9	Benzo(k)fluoranthene ^{b, c}	<1.8E-06	E
106-97-8	Butane	2.1E+00	E
218-01-9	Chrysene ^{b, c}	<1.8E-06	E
53-70-3	Dibenzo(a,h)anthracene ^{b, c}	<1.2E-06	E
25321-22-6	Dichlorobenzene ^b	1.2E-03	E
74-84-0	Ethane	3.1E+00	E
206-44-0	Fluoranthene ^{b, c}	3.0E-06	E
86-73-7	Fluorene ^{b, c}	2.8E-06	E
50-00-0	Formaldehyde ^b	7.5E-02	B
110-54-3	Hexane ^b	1.8E+00	E
193-39-5	Indeno(1,2,3-cd)pyrene ^{b, c}	<1.8E-06	E
91-20-3	Naphthalene ^b	6.1E-04	E
109-66-0	Pentane	2.6E+00	E
85-01-8	Phenanathrene ^{b, c}	1.7E-05	D
74-98-6	Propane	1.6E+00	E

TABLE 1.4-3. EMISSION FACTORS FOR SPECIATED ORGANIC COMPOUNDS FROM NATURAL GAS COMBUSTION (Continued)

CAS No.	Pollutant	Emission Factor (lb/10 ⁶ scf)	Emission Factor Rating
129-00-0	Pyrene ^{b, c}	5.0E-06	E
108-88-3	Toluene ^b	3.4E-03	C

- ^a Reference 11. Units are in pounds of pollutant per million standard cubic feet of natural gas fired. Data are for all natural gas combustion sources. To convert from lb/10⁶ scf to kg/10⁶ m³, multiply by 16. To convert from lb/10⁶ scf to lb/MMBtu, divide by 1,020. Emission Factors preceded with a less-than symbol are based on method detection limits.
- ^b Hazardous Air Pollutant (HAP) as defined by Section 112(b) of the Clean Air Act.
- ^c HAP because it is Polycyclic Organic Matter (POM). POM is a HAP as defined by Section 112(b) of the Clean Air Act.
- ^d The sum of individual organic compounds may exceed the VOC and TOC emission factors due to differences in test methods and the availability of test data for each pollutant.

Section 8

Map(s)

A map such as a 7.5 minute topographic quadrangle showing the exact location of the source. The map shall also include the following:

The UTM or Longitudinal coordinate system on both axes	An indicator showing which direction is north
A minimum radius around the plant of 0.8km (0.5 miles)	Access and haul roads
Topographic features of the area	Facility property boundaries
The name of the map	The area which will be restricted to public access
A graphical scale	

A topographical map is included in this section.

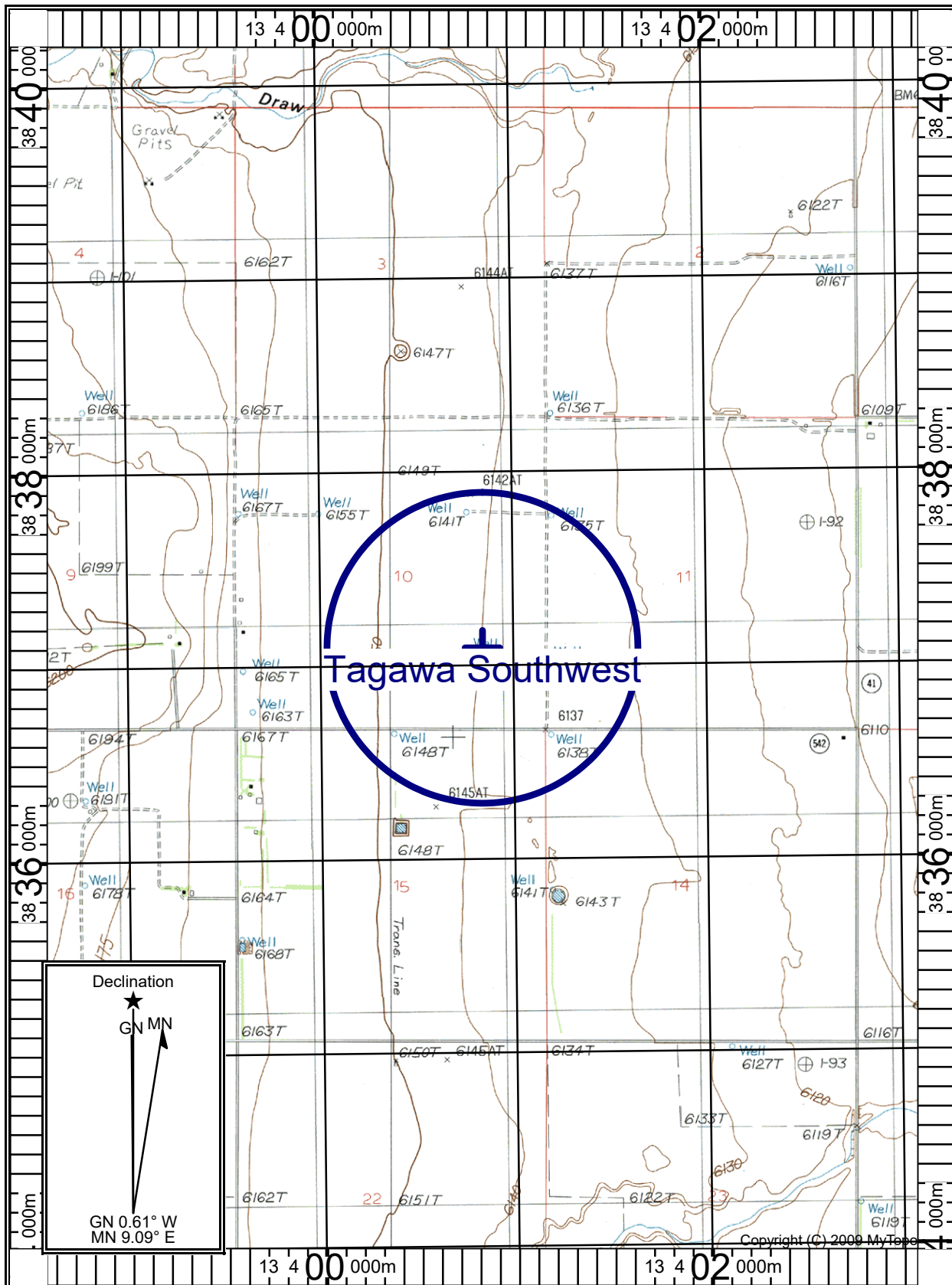

Map Name: MOUNTAINAIR NE
 Print Date: 09/16/22
 Scale: 1 inch = 2,500 ft.
 Map Center: 13 0400839 E 3837089 N
 Horizontal Datum: WGS84

Section 9

Proof of Public Notice

(for NSR applications submitting under 20.2.72 or 20.2.74 NMAC)

(This proof is required by: 20.2.72.203.A.14 NMAC “Documentary Proof of applicant’s public notice”)

I have read the AQB “Guidelines for Public Notification for Air Quality Permit Applications”

This document provides detailed instructions about public notice requirements for various permitting actions. It also provides public notice examples and certification forms. Material mistakes in the public notice will require a re-notice before issuance of the permit.

Unless otherwise allowed elsewhere in this document, the following items document proof of the applicant’s Public Notification. Please include this page in your proof of public notice submittal with checkmarks indicating which documents are being submitted with the application.

New Permit and **Significant Permit Revision** public notices must include all items in this list.

Technical Revision public notices require only items 1, 5, 9, and 10.

Per the Guidelines for Public Notification document mentioned above, include:

1. A copy of the certified letter receipts with post marks (20.2.72.203.B NMAC)
2. A list of the places where the public notice has been posted in at least four publicly accessible and conspicuous places, including the proposed or existing facility entrance. (e.g: post office, library, grocery, etc.)
3. A copy of the property tax record (20.2.72.203.B NMAC).
4. A sample of the letters sent to the owners of record.
5. A sample of the letters sent to counties, municipalities, and Indian tribes.
6. A sample of the public notice posted and a verification of the local postings.
7. A table of the noticed citizens, counties, municipalities and tribes and to whom the notices were sent in each group.
8. A copy of the public service announcement (PSA) sent to a local radio station and documentary proof of submittal.
9. A copy of the classified or legal ad including the page header (date and newspaper title) or its affidavit of publication stating the ad date, and a copy of the ad. When appropriate, this ad shall be printed in both English and Spanish.
10. A copy of the display ad including the page header (date and newspaper title) or its affidavit of publication stating the ad date, and a copy of the ad. When appropriate, this ad shall be printed in both English and Spanish.
11. A map with a graphic scale showing the facility boundary and the surrounding area in which owners of record were notified by mail. This is necessary for verification that the correct facility boundary was used in determining distance for notifying land owners of record.

All public notice requirements above have been satisfied for this significant revision application.

General Posting of Notices – Certification

I, Pat LoPachin, the undersigned, certify that on {9/16/2022}, posted a true and correct copy of the attached Public Notice in the following publicly accessible and conspicuous places in the {CITY\TOWN\VILLAGE} of {TORRANCE} County, State of New Mexico on the following dates:

1. Facility entrance {9/16/2022} – Tagawa Greenhouse
2. {Location 2} Torrance Post Office {9/16/2022}
3. {Location 3} EMW GAS CO. {9/16/22}
4. {Location 4} Estancia Library {9/16/2022}

Signed this 16 day of September, 2022.

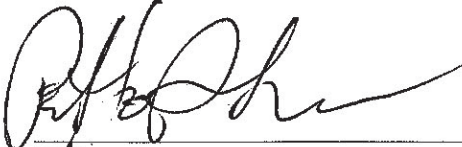

Signature

9/16/22

Date

Pat LoPachin

Printed Name

G.M.

Title {APPLICANT OR RELATIONSHIP TO APPLICANT}

geometry	UPC	Account Number	Owner	Owner Address	Site Address	Acreage	Legal Description	Tax Area	Account Type	Subdivision	Land Value	Improvement Value
Geocortex.Gis.Geometries.Polygon	1.04603E+18		TOM & JERRY RANCHES LLC	12437 CHELWOOD PL NE ALBUQUERQUE NM 871124625	31 N LA TRENCHERITA RD	145.28	Quarter: SW S: 10 T: 5N R: 8E SUTUS INFORMATION: 31 N LA TRENCHERITA RD, SECTION 10 TOWNSHIP 5N RANGE BE LANDS OF HAROLD J JONES TR B 145.578AC WITHIN SW4 SURVEY D/338	70UTETON	Agricultural		\$25,868.00	\$4,099.00
Geocortex.Gis.Geometries.Polygon	1.04603E+18		RED DOC LAND LLC	703 S CHRISTOPHER DR BELEN NM 870022617	1387 STATE HIGHWAY 542	227.73	Tract: B 4 S: 16 T: 5N R: 8E WITHIN NE4 & W/2E4 LANDS OF PATRICK & CHRISTINE ROGERS F2/315 (227.73)	70UTETON	Agricultural		\$25,868.00	\$7,066.00
Geocortex.Gis.Geometries.Polygon	1.04603E+18		HUMPHRIES LEROY J	HC 68 BOX 71 WILLARD NM 870639701		160	Quarter: SE S: 3 T: 5N R: 8E SECTION 3 T5N R8E SE4	70UTETON	Agricultural		\$792.00	\$0.00
Geocortex.Gis.Geometries.Polygon	1.04503E+18		TOM & JERRY RANCHES	12437 CHELWOOD PL NE ALBUQUERQUE NM 871124625	53 S LA TRENCHERITA RD	80	Quarter: SE S: 16 T: 5N R: 8E SUTUS INFORMATION: 53 S LA TRENCHERITA RD, TRACT T1 TWO-B LANDS OF TOM AND JERRY RANCHES LLC SURVEY F/207 AKA SECTION 16 T5N R8E E2SE4 INCLUDES 1 AC HOMESITE 80 ACRES	70UTETON	Residential		\$10,081.00	\$9,809.00
Geocortex.Gis.Geometries.Polygon	1.04603E+18		PARSONAGE PROPERTIES LLC	PO BOX 7061 ABILENE TX 796087061		140	S: 3 T: 5N R: 8E SECTION 3 T5N R8E LANDS OF BERKSHIRE AND OBERG TRACT 4 (140 ACRES) SURVEY E/321	70UTETON	Agricultural		\$693.00	\$0.00
Geocortex.Gis.Geometries.Polygon	1.04703E+18		TOM & JERRY RANCHES	12437 CHELWOOD PL NE ALBUQUERQUE NM 871124625		960.84	S: 3 T: 5N R: 8E S: 11 T: 5N R: 8E TRACT T1 ONE LANDS OF TOM AND JERRY RANCHES LLC SURVEY F/207 AKA SEC 2 S2332AC; SEC 11 ALL (540AC) TWNSN R8EBE (LARRY BURNETT)	70UTETON	Agricultural		\$21,547.00	\$0.00
Geocortex.Gis.Geometries.Polygon	1.04603E+18		PARSONAGE PROPERTIES LLC	PO BOX 7061 ABILENE TX 796087061		140.15	S: 3 T: 5N R: 8E S: 4 T: 5N R: 8E SECTION 3 & 4 T5N R8E LANDS OF BERKSHIRE AND OBERG TRACT 3 (140.15 ACRES) SURVEY E/321	70UTETON	Agricultural		\$694.00	\$0.00
Geocortex.Gis.Geometries.Polygon	1.04603E+18		TOM & JERRY RANCHES LLC	12437 CHELWOOD PL NE ALBUQUERQUE NM 87112	31 N LA TRENCHERITA RD	1	Quarter: SW S: 10 T: 5N R: 8E SECTION 10 T5N R8E LANDS OF HAROLD J JONES TRACT A 12.39 ACRES WITHIN SW4 SURVEY D-338, SUTUS INFORMATION: 31 N LA TRENCHERITA RD	70UTETON	Residential		\$8,140.00	\$212,112.00
Geocortex.Gis.Geometries.Polygon	1.04603E+18		TOM & JERRY RANCHES LLC	12437 CHELWOOD PL NE ALBUQUERQUE NM 871124625	18 S LA TRENCHERITA RD	1	Quarter: SE S: 15 T: 5N R: 8E SUTUS INFORMATION: 18 S LA TRENCHERITA RD, 1 ACIE HOMESITE IN TRACT T1 TWO-A LANDS OF TOM AND JERRY RANCHES LLC PER SURVEY F/207 LOCATED WITHIN PROPERTY ID 8002105701.	70UTETON	Residential		\$8,923.00	\$71,521.00
Geocortex.Gis.Geometries.Polygon	1.04603E+18		TOM & JERRY RANCHES LLC	12437 CHELWOOD PL NE ALBUQUERQUE NM 871124625	18 S LA TRENCHERITA	1241.45	S: 15 T: 5N R: 8E S: 14 T: 5N R: 8E SUTUS INFORMATION: 18 S LA TRENCHERITA, T5N R8E TRACT T1 TWO-A LANDS OF TOM AND JERRY RANCHES LLC SURVEY F/207 F/K/A ALL SECTION 15 PORTION OF 14 CLAYTON RANCH	70UTETON	Agricultural		\$115,435.00	\$2,146.00
Geocortex.Gis.Geometries.Polygon	1.04603E+18		PETERSON MATTHEW B	161 AKIN FARM RD ESTANCIA NM 870168082	N LA TRENCHERITA RD	160	Quarter: NW S: 10 T: 5N R: 8E SUTUS INFORMATION: N LA TRENCHERITA RD, SEC 10 T5N R8E NW4	70UTETON	Agricultural		\$25,214.00	\$20,202.00
Geocortex.Gis.Geometries.Polygon	1.04703E+18		PARSONAGE PROPERTIES LLC	PO BOX 7061 ABILENE TX 796087061		142.02	S: 2 T: 5N R: 8E S: 3 T: 5N R: 8E S: 34 T: 6N R: 8E S: 35 T: 6N R: 8E SECTION 2 & 3 T5N R8E & SECTION 35 T6N R8E LANDS OF BERKSHIRE AND OBERG TRACT 6 (140.02 ACRES) SURVEY E/321	70UTETON	Agricultural		\$703.00	\$0.00

7014 2870 0001 4722 8661

U.S. Postal Service™
CERTIFIED MAIL® RECEIPT
Domestic Mail Only

For delivery information, visit our website at www.usps.com®.

OFFICIAL

Postage	\$
Certified Fee	
Return Receipt Fee (Endorsement Required)	
Restricted Delivery Fee (Endorsement Required)	
Total Postage & Fees	\$

\$0.00¹
US POSTAGE
9/13/2022
062S12395454
87113
000023088



Sent To Torrance County Manager
Street & Apt. No.,
or PO Box No. P.O. Box 48, 205 S. Ninth St.
City, State, ZIP+4 Estancia, NM 87010

PS Form 3800, July 2014 See Reverse for Instructions

7014 2870 0001 4722 8647

U.S. Postal Service™
CERTIFIED MAIL® RECEIPT
Domestic Mail Only

For delivery information, visit our website at www.usps.com®.

OFFICIAL

Postage	\$
Certified Fee	
Return Receipt Fee (Endorsement Required)	
Restricted Delivery Fee (Endorsement Required)	
Total Postage & Fees	\$

\$0.00¹
US POSTAGE
9/13/2022
062S12395454
87113
000023087



Sent To Willard City Manager
Street & Apt. No.,
or PO Box No. P.O. Box 204
City, State, ZIP+4 Willard, NM 87063

PS Form 3800, July 2014 See Reverse for Instructions

7014 2870 0001 4722 8609

U.S. Postal Service™
CERTIFIED MAIL® RECEIPT
Domestic Mail Only

For delivery information, visit our website at www.usps.com®.

OFFICIAL

Postage	\$
Certified Fee	
Return Receipt Fee (Endorsement Required)	
Restricted Delivery Fee (Endorsement Required)	
Total Postage & Fees	\$

\$0.00¹
US POSTAGE
9/13/2022
062S12395454
87113
000023082



Sent To Humphries, Leroy J.
Street & Apt. No.,
or PO Box No. HC 68 Box 71
City, State, ZIP+4 Willard, NM 87063

PS Form 3800, July 2014 See Reverse for Instructions

7014 2870 0001 4722 8586

U.S. Postal Service™
CERTIFIED MAIL® RECEIPT
Domestic Mail Only

For delivery information, visit our website at www.usps.com®.

OFFICIAL

Postage	\$
Certified Fee	
Return Receipt Fee (Endorsement Required)	
Restricted Delivery Fee (Endorsement Required)	
Total Postage & Fees	\$

\$0.00¹
US POSTAGE
9/13/2022
062S12395454
87113
000023081



Sent To Parsonage Properties, LLC
Street & Apt. No.,
or PO Box No. P.O. Box 7061
City, State, ZIP+4 Abilene, TX 79608

PS Form 3800, July 2014 See Reverse for Instructions

7014 2870 0001 4722 8623

U.S. Postal Service™
CERTIFIED MAIL® RECEIPT
Domestic Mail Only

For delivery information, visit our website at www.usps.com®.

OFFICIAL

Postage	\$
Certified Fee	
Return Receipt Fee (Endorsement Required)	
Restricted Delivery Fee (Endorsement Required)	
Total Postage & Fees	\$

\$0.00¹
US POSTAGE
9/13/2022
062S12395454
87113
000023084



Sent To Red Doc Land, LLC
Street & Apt. No.,
or PO Box No. 703 S. Christopher Dr.
City, State, ZIP+4 Belen, NM 87002

PS Form 3800, July 2014 See Reverse for Instructions

7014 2870 0001 4722 8579

U.S. Postal Service™
CERTIFIED MAIL® RECEIPT
Domestic Mail Only

For delivery information, visit our website at www.usps.com®.

OFFICIAL

Postage	\$
Certified Fee	
Return Receipt Fee (Endorsement Required)	
Restricted Delivery Fee (Endorsement Required)	
Total Postage & Fees	\$

\$0.00¹
US POSTAGE
9/13/2022
062S12395454
87113
000023083



Sent To Matthew B. Peterson
Street & Apt. No.,
or PO Box No. 161 Akin Farm Rd.
City, State, ZIP+4 Estancia, NM 87016

PS Form 3800, July 2014 See Reverse for Instructions

7014 2870 0001 4722 8616

U.S. Postal Service™
CERTIFIED MAIL® RECEIPT
Domestic Mail Only

For delivery information, visit our website at www.usps.com®.

OFFICIAL

Postage	\$
Certified Fee	
Return Receipt Fee (Endorsement Required)	
Restricted Delivery Fee (Endorsement Required)	
Total Postage & Fees	\$

\$0.00⁹
US POSTAGE
9/13/2022
062512395454
87113
000023086



Sent To Estancia City Manager
 Street & Apt. No.,
 or PO Box No. P.O. Box 106
 City, State, ZIP+4 Estancia, NM 87016

7014 2870 0001 4722 8630

U.S. Postal Service™
CERTIFIED MAIL® RECEIPT
Domestic Mail Only

For delivery information, visit our website at www.usps.com®.

OFFICIAL

Postage	\$
Certified Fee	
Return Receipt Fee (Endorsement Required)	
Restricted Delivery Fee (Endorsement Required)	
Total Postage & Fees	\$

\$0.00⁹
US POSTAGE
9/13/2022
062512395454
87113
000023085



Sent To Tom & Jerry Banches, LLC
 Street & Apt. No.,
 or PO Box No. 12437 Chelwood PL. NE
 City, State, ZIP+4 Albuquerque, NM 87112

NOTICE

NOTICE OF AIR QUALITY PERMIT APPLICATION

This notice is required by the California Air Resources Board (CARB) for the proposed project described in the project description. The project description is available at the following website: [www.arb.ca.gov](#)

The project description is available at the following website: [www.arb.ca.gov](#)

Parameter	Standard	Value
PM ₁₀	1.0 µg/m ³	0.05 µg/m ³
PM _{2.5}	0.7 µg/m ³	0.05 µg/m ³
Carbon Monoxide (CO)	4.0 ppm	0.05 ppm
Ozone (O ₃)	0.12 ppm	0.05 ppm
Lead (Pb)	0.15 µg/m ³	0.05 µg/m ³
Total Suspended Particulates (TSP)	1.2 µg/m ³	0.05 µg/m ³

The project description is available at the following website: [www.arb.ca.gov](#)

The project description is available at the following website: [www.arb.ca.gov](#)

The project description is available at the following website: [www.arb.ca.gov](#)

The project description is available at the following website: [www.arb.ca.gov](#)

Parameter	Standard	Value
PM ₁₀	1.0 µg/m ³	0.05 µg/m ³
PM _{2.5}	0.7 µg/m ³	0.05 µg/m ³
Carbon Monoxide (CO)	4.0 ppm	0.05 ppm
Ozone (O ₃)	0.12 ppm	0.05 ppm
Lead (Pb)	0.15 µg/m ³	0.05 µg/m ³
Total Suspended Particulates (TSP)	1.2 µg/m ³	0.05 µg/m ³

Parameter	Standard	Value
PM ₁₀	1.0 µg/m ³	0.05 µg/m ³
PM _{2.5}	0.7 µg/m ³	0.05 µg/m ³
Carbon Monoxide (CO)	4.0 ppm	0.05 ppm
Ozone (O ₃)	0.12 ppm	0.05 ppm
Lead (Pb)	0.15 µg/m ³	0.05 µg/m ³
Total Suspended Particulates (TSP)	1.2 µg/m ³	0.05 µg/m ³

The project description is available at the following website: [www.arb.ca.gov](#)

The project description is available at the following website: [www.arb.ca.gov](#)

The project description is available at the following website: [www.arb.ca.gov](#)

NOTICE OF AIR QUALITY PERMIT APPLICATION

Tagawa Greenhouse Enterprises LLC announces its application submittal to the New Mexico Environment Department for an air quality permit for the modification of its greenhouse facility. The expected date of application submittal to the Air Quality Bureau is September 19, 2022.

The exact location for the proposed facility known as, Tagawa Southwest, is at 1459 State Road 542, Estancia, NM 87016. The approximate location of this facility is 5.4 miles southwest of Estancia in Torrance County.

The proposed modification consists of replacing existing boilers.

The estimated maximum quantities of any regulated air contaminant will be as follows in pound per hour (pph) and tons per year (tpy) and could change slightly during the course of the Department's review:

Pollutant:	Pounds per hour	Tons per year
PM ₁₀	1.27 pph	2.99 tpy
PM _{2.5}	1.27 pph	2.99 tpy
Sulfur Dioxide (SO ₂)	0.51 pph	2.24 tpy
Nitrogen Oxides (NO _x)	10.75 pph	29.12 tpy
Carbon Monoxide (CO)	7.52 pph	32.96 tpy
Volatile Organic Compounds (VOC)	0.49 pph	3.35 tpy
Total sum of all Hazardous Air Pollutants (HAPs)	60.35 pph	2.90 tpy

The standard and maximum operating schedules of the facility will be 24 hours per day, 7 days a week and a maximum of 52 weeks per year.

The owner and/or operator of the Facility is: Pat Lopachin; Tagawa Greenhouse Enterprises; 1459 State Road 542, Estancia, NM 87016.

If you have any comments about the construction or operation of this facility, and you want your comments to be made as part of the permit review process, you must submit your comments in writing to this address: Permit Programs Manager; New Mexico Environment Department; Air Quality Bureau; 525 Camino de los Marquez, Suite 1; Santa Fe, New Mexico; 87505-1816. Other comments and questions may be submitted verbally. (505) 476-4300; 1 800 224-7009.

Please refer to the company name and site name, or send a copy of this notice along with your comments, since the Department may have not yet received the permit application. Please include a legible return mailing address with your comments. Once the Department has performed a preliminary review of the application and its air quality impacts, the Department's notice will be published in the legal section of a newspaper circulated near the facility location.

General information about air quality and the permitting process, and links to the regulations can be found at the Air Quality Bureau's website: www.env.nm.gov/air-quality/permitting-section-home-page/. The regulation dealing with public participation in the permit review process is 20.2.72.206 NMAC.

Atención

Este es un aviso de la oficina de Calidad del Aire del Departamento del Medio Ambiente de Nuevo México, acerca de las emisiones producidas por un establecimiento en esta área. Si usted desea información en español, por favor comuníquese con esa oficina al teléfono 505-372-8373.

Notice of Non-Discrimination

NMED does not discriminate on the basis of race, color, national origin, disability, age or sex in the administration of its programs or activities, as required by applicable laws and regulations. NMED is responsible for coordination of compliance efforts and receipt of inquiries concerning non-discrimination requirements implemented by 40 C.F.R. Part 7, including Title VI of the Civil Rights Act of 1964, as amended; Section 504 of the Rehabilitation Act of 1973; the Age Discrimination Act of 1975, Title IX of the Education Amendments of 1972, and Section 13 of the Federal Water Pollution Control Act Amendments of 1972. If you have any questions about this notice or any of NMED's non-discrimination programs, policies or procedures, or if you believe that you have been discriminated against with respect to a NMED program or activity, you may contact: Kathryn Becker, Non-Discrimination Coordinator, NMED, 1190 St. Francis Dr., Suite N4050, P.O. Box 5469, Santa Fe, NM 87502, (505) 827-2855, nd.coordinator@state.nm.us. You may also visit our website at <https://www.env.nm.gov/non-employee-discrimination-complaint-page/> to learn how and where to file a complaint of discrimination.

September 13, 2022

CERTIFIED MAIL XXXX XXXX XXXX XXXX
RETURN RECEIPT REQUESTED (certified mail is required, return receipt is optional)

Dear «Owner»,

Tagawa Greenhouse Enterprises LLC announces its application submittal to the New Mexico Environment Department for an air quality permit for the modification of its greenhouse facility. The expected date of application submittal to the Air Quality Bureau is September 19, 2022.

The exact location for the proposed facility known as, Tagawa Southwest, is at 1459 State Road 542, Estancia, NM 87016. The approximate location of this facility is 5.4 miles southwest of Estancia in Torrance County.

The proposed modification consists of replacing existing boilers.

The estimated maximum quantities of any regulated air contaminant will be as follows in pound per hour (pph) and tons per year (tpy) and may change slightly during the course of the Department's review:

Pollutant:	Pounds per hour	Tons per year
PM ₁₀	1.27 pph	2.99 tpy
PM _{2.5}	1.27 pph	2.99 tpy
Sulfur Dioxide (SO ₂)	0.51 pph	2.24 tpy
Nitrogen Oxides (NO _x)	10.75 pph	29.12 tpy
Carbon Monoxide (CO)	7.52 pph	32.96 tpy
Volatile Organic Compounds (VOC)	0.49 pph	3.35 tpy
Total sum of all Hazardous Air Pollutants (HAPs)	60.35 pph	2.90 tpy

The standard and maximum operating schedules of the facility will be 24 hours per day, 7 days a week and a maximum of 52 weeks per year

Owners and operators of the facility include Pat Lopachin.

If you have any comments about the construction or operation of this facility, and you want your comments to be made as part of the permit review process, you must submit your comments in writing to this address: Permit Programs Manager; New Mexico Environment Department; Air Quality Bureau; 525 Camino de los Marquez, Suite 1; Santa Fe, New Mexico; 87505-1816. Other comments and questions may be submitted verbally. (505) 476-4300; 1 800 224-7009.

Please refer to the company name and facility name, or send a copy of this notice along with your comments, since the Department may have not yet received the permit application. Please include a legible return mailing address with your comments. Once the Department has performed a preliminary review of the application and its air quality impacts, the Department's notice will be published in the legal section of a newspaper circulated near the facility location.

Atención

Este es un aviso de la oficina de Calidad del Aire del Departamento del Medio Ambiente de Nuevo México, acerca de las emisiones producidas por un establecimiento en esta área. Si usted desea información en español, por favor comuníquese con esa oficina al teléfono 505-372-8373.

Sincerely,
Tagawa Greenhouse Enterprises LLC
1459 State Road 542
Estancia, New Mexico 87016

Notice of Non-Discrimination

NMED does not discriminate on the basis of race, color, national origin, disability, age or sex in the administration of its programs or activities, as required by applicable laws and regulations. NMED is responsible for coordination of compliance efforts and receipt of inquiries concerning non-discrimination requirements implemented by 40 C.F.R. Part 7, including Title VI of the Civil Rights Act of 1964, as amended; Section 504 of the Rehabilitation Act of 1973; the Age Discrimination Act of 1975, Title IX of the Education Amendments of 1972, and Section 13 of the Federal Water Pollution Control Act Amendments of 1972. If you have any questions about this notice or any of NMED's non-discrimination programs, policies or procedures, or if you believe that you have been discriminated against with respect to a NMED program or activity, you may contact: Kathryn Becker, Non-Discrimination Coordinator, NMED, 1190 St. Francis Dr., Suite N4050, P.O. Box 5469, Santa Fe, NM 87502, (505) 827-2855, nd.coordinator@state.nm.us. You may also visit our website at <https://www.env.nm.gov/non-employee-discrimination-complaint-page/> to learn how and where to file a complaint of discrimination.

September 13, 2022

CERTIFIED MAIL XXXX XXXX XXXX XXXX

RETURN RECEIPT REQUESTED (certified mail is required, return receipt is optional)

Dear **[Neighbor/Environmental Director/county or municipal official]**

Tagawa Greenhouses Enterprises LLC announces its application submittal to the New Mexico Environment Department for an air quality permit for the modification of its greenhouse facility. The expected date of application submittal to the Air Quality Bureau is September 19, 2022.

The exact location for the proposed facility known as, Tagawa Southwest, is at 1459 State Road 54, Estancia, NM 87016. The approximate location of this facility is 5.4 miles southwest of Estancia in Torrance County.

The proposed modification consists of replacing existing boilers.

The estimated maximum quantities of any regulated air contaminant will be as follows in pound per hour (pph) and tons per year (tpy) and may change slightly during the course of the Department's review:

Pollutant:	Pounds per hour	Tons per year
PM ₁₀	1.27 pph	2.99 tpy
PM _{2.5}	1.27 pph	2.99 tpy
Sulfur Dioxide (SO ₂)	0.51 pph	2.24 tpy
Nitrogen Oxides (NO _x)	10.75 pph	29.12 tpy
Carbon Monoxide (CO)	7.52 pph	32.96 tpy
Volatile Organic Compounds (VOC)	0.49 pph	3.35 tpy
Total sum of all Hazardous Air Pollutants (HAPs)	60.35 pph	2.90 tpy

The standard and maximum operating schedules of the facility will be 24 hours per day, 7 days a week and a maximum of 52 weeks per year.

Owners and operators of the facility include Pat Lopachin.

If you have any comments about the construction or operation of this facility, and you want your comments to be made as part of the permit review process, you must submit your comments in writing to this address: Permit Programs Manager; New Mexico Environment Department; Air Quality Bureau; 525 Camino de los Marquez, Suite 1; Santa Fe, New Mexico; 87505-1816. Other comments and questions may be submitted verbally. (505) 476-4300; 1 800 224-7009.

Please refer to the company name and facility name, or send a copy of this notice along with your comments, since the Department may have not yet received the permit application. Please include a legible return mailing address with your comments. Once the Department has performed a preliminary review of the application and its air quality impacts, the Department's notice will be published in the legal section of a newspaper circulated near the facility location.

Atención

Este es un aviso de la oficina de Calidad del Aire del Departamento del Medio Ambiente de Nuevo México, acerca de las emisiones producidas por un establecimiento en esta área. Si usted desea información en español, por favor comuníquese con esa oficina al teléfono 505-372-8373.

Sincerely,
Pat Lopachin
1459 State Road 542
Estancia, NM 87106

Notice of Non-Discrimination

NMED does not discriminate on the basis of race, color, national origin, disability, age or sex in the administration of its programs or activities, as required by applicable laws and regulations. NMED is responsible for coordination of compliance efforts and receipt of inquiries concerning non-discrimination requirements implemented by 40 C.F.R. Part 7, including Title VI of the Civil Rights Act of 1964, as amended; Section 504 of the Rehabilitation Act of 1973; the Age Discrimination Act of 1975, Title IX of the Education Amendments of 1972, and Section 13 of the Federal Water Pollution Control Act Amendments of 1972. If you have any questions about this notice or any of NMED's non-discrimination programs, policies or procedures, or if you believe that you have been discriminated against with respect to a NMED program or activity, you may contact: Kathryn Becker, Non-Discrimination Coordinator, NMED, 1190 St. Francis Dr., Suite N4050, P.O. Box 5469, Santa Fe, NM 87502, (505) 827-2855, nd.coordinator@state.nm.us. You may also visit our website at <https://www.env.nm.gov/non-employee-discrimination-complaint-page/> to learn how and where to file a complaint of discrimination.

Section 9
Tagawa Southwest

Property Owners	
Owner Name	Address
TOM & JERRY RANCHS LLC	12437 CHELWOOD PL NE ALBUQUERQUE NM 871124625
RED DOC LAND LLC	703 S CHRISTOPHER DR BELEN NM 870022617
HUMPHRIES LEROY J	HC 68 BOX 71 WILLARD NM 870639701
PARSONAGE PROPERTIES LLC	PO BOX 7061 ABILENE TX 796087061
PETERSON MATTHEW B	161 AKIN FARM RD ESTANCIA NM 870168082
Tribes	
N/A	
Counties	
County	Contact - Adress
Torrance	Torrance County Manager - P.O. Box 48, 205 S. Ninth St., Estancia, NM 87016
Municipalities	
City	Contact - Adress
Estancia	Estancia City Manager - P.O. Box 166, Estancia, NM 87016
Willard	Willard City Manager - P.O. Box 204, Willard, NM 87063

From: [Jaimy Karacaoglu](mailto:jaimy.karacaoglu@trinityconsultants.com)
To: ["info@kxnm.org"](mailto:info@kxnm.org)
Cc: [Adam Erenstein](mailto:adam.erenstein@trinityconsultants.com)
Subject: Tagawa Southwest Public Service Announcement
Date: Monday, September 19, 2022 4:20:54 PM
Attachments: [image001.png](#)

Dear Radio 88.7 KXNM-FM,

Per New Mexico Administrative Code 20.2.72.203.B NMAC and according to the Guidance for Public Notice for Air Quality Permit Applications – **(5) Notifications: Submittal of Public Service Announcement (PSA):** A public service announcement required for permits and significant permit revisions must be submitted to at least one radio or television station, which services the municipality, or county which the facility is or will be located. **Therefore, based on the above, we respectfully ask you to air the information shown below as a Public Service Announcement.**

The public service announcement request must contain the following information about the facility or proposed facility (20.2.72.203.D NMAC).

- a. The name: **Tagawa Southwest**, location: **1459 State Road 542, Estancia, NM 87016** and type of business: **greenhouse facility.**
- b. The name and principal owner or operator: **Tagawa Greenhouse Enterprises, LLC** – owner and operator.
- c. The type of process or change for which the permit is sought: **NSR Significant Revision – removal of one boiler and installation of two new boilers.**
- d. Locations where the notices have been posted in Estancia, NM 87016: **(1) Tagawa Southwest Facility Entrance - 1459 State Road 542, Estancia, NM 87016 (2) Torrance Post Office - 413 E. Highland Ave, Estancia, NM 87016 (3) EMW Gas Co. - 416 5th St., Estancia, NM 87016 (4) Estancia Library - 601 10th St., Estancia, NM 87016.**
- e. The Department's address or telephone number to which comments may be directed: **Permit Programs manager; New Mexico Environment Department; Air Quality Bureau; 525 Camino de los Marquez, Suite 1, Santa Fe, New Mexico; 87505-1816; (505) 476-4300; 1 (800) 224-7009.**

Regards,

Jaimy Karacaoglu
Consultant

M 410.903.0750
9400 Holly Avenue NE, Building 3, Suite B, Albuquerque, NM 87122
Email: jaimy.karacaoglu@trinityconsultants.com



Connect with us: [LinkedIn](#) / [Facebook](#) / [Twitter](#) / [YouTube](#) / trinityconsultants.com

Stay current on environmental issues. [Subscribe](#) today to receive Trinity's free *EHS Quarterly*.

Submittal of Public Service Announcement – Certification

I, Jaimy Karacaoglu, the undersigned, certify that on **September 19, 2022**, submitted a public service announcement to **Radio 88.7 KXNM-FM** that serves the City of **Estancia, Torrance** County, New Mexico, in which the source is or is proposed to be located and that **Radio 88.7 KXNM-FM DID NOT RESPOND**.

Signed this 21 day of September, 2022.

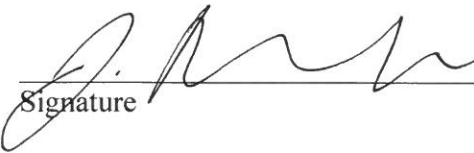
Signature

09/21/2022
Date

Jaimy Karacaoglu
Printed Name

Consultant
Title {APPLICANT OR RELATIONSHIP TO APPLICANT}

Mail and Copy Business Center
 Shipping and Drop-off Location
 UPS Federal Express
 Copy Services
 Notary M-F 8-6
 Fax Sat 9-2
 Business Cards
 Laminating
 Bulk Mailing
 2 Marietta Ct Suite A
 Edgewood, NM 87015
 (Right across from Tractor Supply) 505-281-2400

MORIARTY Concrete Products
MCP Redi-Mix Concrete
 Crushed Rock • All Sizes Road Base
 Boulders • Crusher Fines • Septic Rock
 Rip-Rap • Backfill Concrete • Plaster Sand
832-4739
 Quality Products at Competitive Prices!

NOTICE OF AIR QUALITY PERMIT APPLICATION

Tagawa Greenhouse Enterprises LLC announces its application submittal to the New Mexico Environment Department for an air quality permit for the modification of its greenhouse facility. The expected date of application submittal to the Air Quality Bureau is September 19, 2022.

The exact location for the proposed facility known as, Tagawa Southwest, is at 1459 State Road 542, Estancia, NM 87016. The approximate location of this facility is 5.4 miles southwest of Estancia in Torrance County.

The proposed modification consists of replacing existing boilers.

The estimated maximum quantities of any regulated air contaminant will be as follows in pound per hour (pph) and tons per year (tpy) and could change slightly during the course of the Department's review:

Pollutant:	Pounds per hour	Tons per year
PM ₁₀	1.27 pph	2.99 tpy
PM _{2.5}	1.27 pph	2.99 tpy
Sulfur Dioxide (SO ₂)	0.51 pph	2.24 tpy
Nitrogen Oxides (NO _x)	10.75 pph	29.12 tpy
Carbon Monoxide (CO)	7.52 pph	32.96 tpy
Volatile Organic Compounds (VOC)	0.49 pph	3.35 tpy
Total sum of all Hazardous Air Pollutants (HAPs)	60.35 pph	2.90 tpy

The standard and maximum operating schedules of the facility will be 24 hours per day, 7 days a week and a maximum of 52 weeks per year.

The owner and/or operator of the Facility is:
 Pat Lopachin; Tagawa Greenhouse Enterprises;
 1459 State Road 542, Estancia, NM 87016.

If you have any comments about the construction or operation of this facility, and you want your comments to be made as part of the permit review process, you must submit your comments in writing to this address: Permit Programs Manager; New Mexico Environment Department; Air Quality Bureau; 525 Camino de los Marquez, Suite 1; Santa Fe, New Mexico; 87505-1816. Other comments and questions may be submitted verbally. (505) 476-4300; 1 800 224-7009.

Please refer to the company name and site name, or send a copy of this notice along with your comments, since the Department may have not yet received the permit application. Please include a legible return mailing address with your comments. Once the Department has performed a preliminary review of the application and its air quality impacts, the Department's notice will be published in the legal section of a newspaper circulated near the facility location.

General information about air quality and the permitting process, and links to the regulations can be found at the Air Quality Bureau's website: www.env.nm.gov/air-quality/permitting-section-home-page/. The regulation dealing with public participation in the permit review process is 20.2.72.206 NMAC.

Atención

Este es un aviso de la oficina de Calidad del Aire del Departamento del Medio Ambiente de Nuevo México, acerca de las emisiones producidas por un establecimiento en esta área. Si usted desea información en español, por favor comuníquese con esa oficina al teléfono 505-372-8373.

Notice of Non-Discrimination

NMED does not discriminate on the basis of race, color, national origin, disability, age or sex in the administration of its programs or activities, as required by applicable laws and regulations. NMED is responsible for coordination of compliance efforts and receipt of inquiries concerning non-discrimination requirements implemented by 40 C.F.R. Part 7, including Title VI of the Civil Rights Act of 1964, as amended; Section 504 of the Rehabilitation Act of 1973; the Age Discrimination Act of 1975, Title IX of the Education Amendments of 1972, and Section 13 of the Federal Water Pollution Control Act Amendments of 1972. If you have any questions about this notice or any of NMED's non-discrimination programs, policies or procedures, or if you believe that you have been discriminated against with respect to a NMED program or activity, you may contact: Kathryn Becker, Non-Discrimination Coordinator, NMED, 1190 St. Francis Dr., Suite N4050, P.O. Box 5469, Santa Fe, NM 87502, (505) 827-2855, nd.coordinator@state.nm.us. You may also visit our website at <https://www.env.nm.gov/non-employee-discrimination-complaint-page/> to learn how and where to file a complaint of discrimination.

HARRIS-HANLON MORTUARY
 "Our Family Serving Your Family"

Natural Green Burials
Low Cost Cremation
Pet Cremation
 Grant & Karen Preston, Funeral Directors
 Moriarty 505-832-6130 • 505-847-2331 Mountainair



BRING IN THIS AD FOR 10% OFF YOUR NEXT PURCHASE!
SHOP LOCAL, SHOP QUALITY!
2 MARIETTA CT, EDGEWOOD NM
MON-SAT 9A-6P
VERVEHEALTHSHOP.COM

The Independent's CLASSIFIED ADS

Ads in our classifieds get results!

Line Ads: Up to 20 words is \$6 + tax
For more than 20 words ad 25¢ a word

Display Ads: As low as \$8 per week!
All display ads include free color. To
place your ad contact 505-286-1212 or
news.ind.ads@gmail.com today!

LEGAL NOTICE

STATE OF NEW MEXICO
COUNTY OF BERNALILLO
SECOND JUDICIAL DISTRICT COURT

NOTICE OF PENDENCY OF ACTION

THE STATE OF NEW MEXICO TO THE FOLLOWING NAMED OR DESIGNATED DEFENDANT:
Mary F. Schlather

KIRTLAND FEDERAL CREDIT UNION, Plaintiff,

NO. D-202-CV-2022-03572

GREETINGS DEFENDANT(S):

MARY F. SCHLATHER, Defendant.

You are hereby notified

that Kirtland Federal Credit Union, as Plaintiff, has filed an action in the Second Judicial District Court of Bernalillo County, New Mexico, and wherein the said Plaintiff seeks to obtain constructive service of process upon you.

The general object of said action is: Civil Complaint for Debt Due

You are further notified that unless you serve a pleading or motion in response to the complaint in said cause on or before thirty (30) days after the last publication date, judgment will be entered against you.

The name and post office address of the Attorneys for the Plaintiff is as follows: Aldridge, Hammar & Wexler, P.A., 1212

Pennsylvania, NE, Albuquerque, New Mexico 87110.

WITNESS the Honorable Beatrice J. Brickhouse, District Judge of the Second Judicial District Court of the State of New Mexico, and the seal of the District Court of Bernalillo County on August 18, 2022.

FILED

2ND JUDICIAL DISTRICT COURT Bernalillo County 8/18/2022 12:24 PM
CLERK OF THE COURT
Angela M Simpson

KATINA WATSON
CLERK OF THE DISTRICT COURT
By: /s/ Angela Simpson Deputy

09/09/2022, 09/16/2022 and 09/23/2022

LEGAL NOTICE

NOTICE OF AIR QUALITY PERMIT APPLICATION

slightly during the course of the Department's review:

Tagawa Greenhouse Enterprises LLC announces its application submittal to the New Mexico Environment Department for an air quality permit for the modification of its greenhouse facility. The expected date of application submittal to the Air Quality Bureau is September 19, 2022.

Pollutant:
Pounds per hour
Tons per year

PM 10
1.27 pph
2.99 tpy

PM 2.5
1.27 pph
2.99 tpy

Sulfur Dioxide (SO2)
0.51 pph
2.24 tpy

Nitrogen Oxides (NOx)
10.75 pph
29.12 tpy

Carbon Monoxide (CO)
7.52 pph
32.96 tpy

Volatile Organic Compounds (VOC)
0.49 pph
3.35 tpy

Total sum of all Hazardous Air Pollutants (HAPs)
60.35 pph
2.90 tpy

The exact location for the proposed facility known as, Tagawa Southwest, is at 1459 State Road 542, Estancia, NM 87016. The approximate location of this facility is 5.4 miles southwest of Estancia in Torrance County.

The proposed modification consists of replacing existing boilers. The estimated maximum quantities of any regulated air contaminant will be as follows in pound per hour (pph) and tons per year (tpy) and could change

The standard and maximum operating schedules of the facility will be 24 hours per day, 7 days a week and a maximum of 52 weeks per year.

The owner and/or operator of the Facility is: Pat Lopachin; Tagawa Greenhouse Enterprises; 1459 State Road 542, Estancia, NM 87016.

If you have any comments about the construction or operation of this facility, and you want your comments to be made as part of the permit review process, you must submit your comments in writing to this address: Permit Programs Manager; New Mexico Environment Department; Air Quality Bureau; 525 Camino de los Marquez, Suite 1; Santa Fe, New Mexico; 87505-1816. Other comments and questions may be submitted verbally. (505) 476-4300; 1 800 224-7009.

Please refer to the company name and site name, or send a copy of this notice along with your comments, since the Department may have not yet received the permit application. Please include a legible return mailing address with your comments. Once the Department has performed a preliminary review of the application and its air quality impacts, the Department's notice will be published in the legal section of a newspaper circulated near the facility location.

General information about air quality and the permitting process, and links to the regulations can be found at the Air Quality Bureau's website: www.env.nm.gov/air-quality/permitting-section-home-page/. The regulation dealing with public participation in the permit review process is 20.2.72.206 NMAC.

Atención
Este es un aviso de la oficina de Calidad del Aire del Departamento del Medio Ambiente de Nuevo México, acerca de las emisiones producidas por un establecimiento en esta área. Si usted desea información en español, por favor comuníquese con esa oficina al teléfono 505-372-8373.

Notice of Non-Discrimination

NMED does not discriminate on the basis of race, color, national origin, disability, age or sex in the administration of its programs or activities, as required by applicable laws and regulations. NMED is responsible for coordination of compliance efforts and receipt of inquiries concerning non-discrimination requirements implemented by 40 C.F.R. Part 7, including Title VI of the Civil Rights Act of 1964, as amended; Sec-

tion 504 of the Rehabilitation Act of 1973; the Age Discrimination Act of 1975, Title IX of the Education Amendments of 1972, and Section 13 of the Federal Water Pollution Control Act Amendments of 1972. If you have any questions about this notice or any of NMED's non-discrimination programs, policies or procedures, or if you believe that you have been discriminated against with respect to a NMED program or activity, you may contact: Kathryn Becker, Non-Discrimination Coordinator, NMED, 1190 St. Francis Dr., Suite N4050, P.O. Box 5469, Santa Fe, NM 87502, (505) 827-2855, nd-coordinator@state.nm.us. You may also visit our website at <https://www.env.nm.gov/non-employee-discrimination-complaint-page/> to learn how and where to file a complaint of discrimination.
09/16/2022

GOT LEGAL NOTICES?

Place online at edgewoodnews.column.us

Section 10

Written Description of the Routine Operations of the Facility

A written description of the routine operations of the facility. Include a description of how each piece of equipment will be operated, how controls will be used, and the fate of both the products and waste generated. For modifications and/or revisions, explain how the changes will affect the existing process. In a separate paragraph describe the major process bottlenecks that limit production. The purpose of this description is to provide sufficient information about plant operations for the permit writer to determine appropriate emission sources.

Tagawa Southwest is an enclosed greenhouse. Boilers (Units 1, 2, and 3) are used to heat the greenhouse that serves as annual bedding plants and perennials for wholesale distribution to other greenhouse companies and retailers. Boilers will routinely be operated with natural gas. In emergency situations, diesel fuel maybe used to fire the boilers.

Section 11

Source Determination

Source submitting under 20.2.70, 20.2.72, 20.2.73, and 20.2.74 NMAC

Sources applying for a construction permit, PSD permit, or operating permit shall evaluate surrounding and/or associated sources (including those sources directly connected to this source for business reasons) and complete this section. Responses to the following questions shall be consistent with the Air Quality Bureau's permitting guidance, Single Source Determination Guidance, which may be found on the Applications Page in the Permitting Section of the Air Quality Bureau website.

Typically, buildings, structures, installations, or facilities that have the same SIC code, that are under common ownership or control, and that are contiguous or adjacent constitute a single stationary source for 20.2.70, 20.2.72, 20.2.73, and 20.2.74 NMAC applicability purposes. Submission of your analysis of these factors in support of the responses below is optional, unless requested by NMED.

A. Identify the emission sources evaluated in this section (list and describe):

All emission sources listed in Table 2-A of this application.

B. Apply the 3 criteria for determining a single source:

SIC Code: Surrounding or associated sources belong to the same 2-digit industrial grouping (2-digit SIC code) as this facility, OR surrounding or associated sources that belong to different 2-digit SIC codes are support facilities for this source.

Yes **No**

Common Ownership or Control: Surrounding or associated sources are under common ownership or control as this source.

Yes **No**

Contiguous or Adjacent: Surrounding or associated sources are contiguous or adjacent with this source.

Yes **No**

C. Make a determination:

The source, as described in this application, constitutes the entire source for 20.2.70, 20.2.72, 20.2.73, or 20.2.74 NMAC applicability purposes. If in "A" above you evaluated only the source that is the subject of this application, all "YES" boxes should be checked. If in "A" above you evaluated other sources as well, you must check **AT LEAST ONE** of the boxes "NO" to conclude that the source, as described in the application, is the entire source for 20.2.70, 20.2.72, 20.2.73, and 20.2.74 NMAC applicability purposes.

The source, as described in this application, **does not** constitute the entire source for 20.2.70, 20.2.72, 20.2.73, or 20.2.74 NMAC applicability purposes (A permit may be issued for a portion of a source). The entire source consists of the following facilities or emissions sources (list and describe):

Section 12

Section 12.A

PSD Applicability Determination for All Sources

(Submitting under 20.2.72, 20.2.74 NMAC)

A PSD applicability determination for all sources. For sources applying for a significant permit revision, apply the applicable requirements of 20.2.74.AG and 20.2.74.200 NMAC and to determine whether this facility is a major or minor PSD source, and whether this modification is a major or a minor PSD modification. It may be helpful to refer to the procedures for Determining the Net Emissions Change at a Source as specified by Table A-5 (Page A.45) of the EPA New Source Review Workshop Manual to determine if the revision is subject to PSD review.

A. This facility is:

- a minor PSD source before and after this modification (if so, delete C and D below).
- a major PSD source before this modification. This modification will make this a PSD minor source.
- an existing PSD Major Source that has never had a major modification requiring a BACT analysis.
- an existing PSD Major Source that has had a major modification requiring a BACT analysis
- a new PSD Major Source after this modification.

B. This facility **[is not]** one of the listed 20.2.74.501 Table I – PSD Source Categories.

Section 13

Determination of State & Federal Air Quality Regulations

This section lists each state and federal air quality regulation that may apply to your facility and/or equipment that are stationary sources of regulated air pollutants.

Not all state and federal air quality regulations are included in this list. Go to the Code of Federal Regulations (CFR) or to the Air Quality Bureau's regulation page to see the full set of air quality regulations.

Required Information for Specific Equipment:

For regulations that apply to specific source types, in the 'Justification' column **provide any information needed to determine if the regulation does or does not apply. For example**, to determine if emissions standards at 40 CFR 60, Subpart IIII apply to your three identical stationary engines, we need to know the construction date as defined in that regulation; the manufacturer date; the date of reconstruction or modification, if any; if they are or are not fire pump engines; if they are or are not emergency engines as defined in that regulation; their site ratings; and the cylinder displacement.

Required Information for Regulations that Apply to the Entire Facility:

See instructions in the 'Justification' column for the information that is needed to determine if an 'Entire Facility' type of regulation applies (e.g. 20.2.70 or 20.2.73 NMAC).

Regulatory Citations for Regulations That Do Not, but Could Apply:

If there is a state or federal air quality regulation that does not apply, but you have a piece of equipment in a source category for which a regulation has been promulgated, you must **provide the low level regulatory citation showing why your piece of equipment is not subject to or exempt from the regulation. For example** if you have a stationary internal combustion engine that is not subject to 40 CFR 63, Subpart ZZZZ because it is an existing 2 stroke lean burn stationary RICE with a site rating of more than 500 brake HP located at a major source of HAP emissions, your citation would be 40 CFR 63.6590(b)(3)(i). **We don't want a discussion of every non-applicable regulation, but if it is possible a regulation could apply, explain why it does not. For example**, if your facility is a power plant, you do not need to include a citation to show that 40 CFR 60, Subpart OOO does not apply to your non-existent rock crusher.

Regulatory Citations for Emission Standards:

For each unit that is subject to an emission standard in a source specific regulation, such as 40 CFR 60, Subpart OOO or 40 CFR 63, Subpart HH, include the low level regulatory citation of that emission standard. Emission standards can be numerical emission limits, work practice standards, or other requirements such as maintenance. **Here are examples:** a glycol dehydrator is subject to the general standards at 63.764C(1)(i) through (iii); an engine is subject to 63.6601, Tables 2a and 2b; a crusher is subject to 60.672(b), Table 3 and all transfer points are subject to 60.672(e)(1)

Federally Enforceable Conditions:

All federal regulations are federally enforceable. All Air Quality Bureau State regulations are federally enforceable except for the following: affirmative defense portions at 20.2.7.6.B, 20.2.7.110(B)(15), 20.2.7.11 through 20.2.7.113, 20.2.7.115, and 20.2.7.116; 20.2.37; 20.2.42; 20.2.43; 20.2.62; 20.2.63; 20.2.86; 20.2.89; and 20.2.90 NMAC. Federally enforceable means that EPA can enforce the regulation as well as the Air Quality Bureau and federally enforceable regulations can count toward determining a facility's potential to emit (PTE) for the Title V, PSD, and nonattainment permit regulations.

INCLUDE ANY OTHER INFORMATION NEEDED TO COMPLETE AN APPLICABILITY DETERMINATION OR THAT IS RELEVANT TO YOUR FACILITY'S NOTICE OF INTENT OR PERMIT.

EPA Applicability Determination Index for 40 CFR 60, 61, 63, etc: <http://cfpub.epa.gov/adi/>

To save paper and to standardize the application format, delete this sentence, and begin your submittal for this attachment on this page.

Example of a Table for State Regulations:

<u>State Regulation Citation</u>	Title	Applies? Enter Yes or No	Unit(s) or Facility	Justification: (You may delete instructions or statements that do not apply in the justification column to shorten the document.)
20.2.1 NMAC	General Provisions	Yes	Facility	General Provisions apply to Notice of Intent, Construction, and Title V permit applications.
20.2.3 NMAC	Ambient Air Quality Standards NMAAQs	Yes	Facility	20.2.3 NMAC is a State Implementation Plan (SIP) approved regulation that limits the maximum allowable concentration of, Sulfur Compounds, Carbon Monoxide and Nitrogen Dioxide. This facility is subject to and complies with applicable air quality standards.
20.2.7 NMAC	Excess Emissions	Yes	Facility	This facility (including individual pieces of equipment) are subject to emission limits as detailed in NSR 2128-M1-R1. As such, this facility is subject to 20.2.7 NMAC and will comply with the excess emission requirements as listed in this regulation.
20.2.23 NMAC	Fugitive Dust Control	No	Facility	This facility is located in an area that does not require a mitigation plan in accordance with 40 CFR Part 51.930. As such, the facility is not subject to the requirements of this regulations.
20.2.33 NMAC	Gas Burning Equipment – Nitrogen Dioxide	No	N/A	This facility has new gas burning equipment having a heat input of greater than 1,000,000 million British Thermal Units per year per unit; therefore, this regulation does not apply.
20.2.34 NMAC	Oil Burning Equipment: NO ₂	No	N/A	This facility has oil burning equipment having a heat input of greater than 1,000,000 million British Thermal Units per year per unit. Units 1, 2, and 3 are dual fuel boilers; therefore, this regulation does not apply.
20.2.35 NMAC	Natural Gas Processing Plant – Sulfur	No	N/A	This facility is not a natural gas processing plant. This regulation does not apply.
20.2.37 and 20.2.36 NMAC	Petroleum Processing Facilities and Petroleum Refineries	N/A	N/A	These regulations were repealed by the Environmental Improvement Board. If you had equipment subject to 20.2.37 NMAC before the repeal, your combustion emission sources are now subject to 20.2.61 NMAC.
20.2.38 NMAC	Hydrocarbon Storage Facility	No	N/A	This facility is not a petroleum production facility, processing facility, tanks battery, or hydrocarbon storage facility. This regulation does not apply.
20.2.39 NMAC	Sulfur Recovery Plant - Sulfur	No	N/A	This facility does not contain the affected source(s). This regulation does not apply.
20.2.50 NMAC	Oil and Gas Sector – Ozone Precursor Pollutants	No	N/A	This regulation establishes emission standards for volatile organic compounds (VOC) and oxides of nitrogen (NO _x) for oil and gas production, processing, compression, and transmission sources. This facility is not an oil and gas production, processing, compression, or transmission facility; therefore, this regulation does not apply.
20.2.61.109 NMAC	Smoke & Visible Emissions	Yes	1, 2, 3	This regulation that limits opacity to 20% applies to Stationary Combustion Equipment, such as engines, boilers, heaters, and flares unless your equipment is subject to another state regulation that limits particulate matter such as 20.2.19 NMAC (see 20.2.61.109 NMAC). This facility has boilers that are considered stationary combustion equipment and is therefore subject to this regulation.
20.2.70 NMAC	Operating Permits	No	Facility	This facility's potential to emit (PTE) is less than 100 tpy of any regulated air pollutant other than HAPS; and less than 10 tpy for a single and less than 25 tpy for combined HAPS. This regulation does not apply.
20.2.71 NMAC	Operating Permit Fees	No	N/A	This facility is not subject to 20.2.70 NMAC therefore it is not subject to 20.2.71 NMAC.
20.2.72 NMAC	Construction Permits	Yes	Facility	This facility's potential emission rate (PER) is greater than 10 pph and greater than 25 tpy for any pollutant subject to a state or federal ambient air quality standard. This regulation applies. This facility is permitted under NSR Permit 2128-M1-R1.

<u>State Regulation Citation</u>	Title	Applies? Enter Yes or No	Unit(s) or Facility	Justification: (You may delete instructions or statements that do not apply in the justification column to shorten the document.)
20.2.73 NMAC	NOI & Emissions Inventory Requirements	Yes	Facility	This facility is subject to Emissions Inventory Reporting per 20.2.73.300 NMAC as the facility emits more than 10 tons of PM ₁₀ , PM _{2.5} , SO _x , NO _x , CO, or VOCs in any calendar year.
20.2.74 NMAC	Permits – Prevention of Significant Deterioration (PSD)	No	N/A	This facility is a stationary source not listed in Table 1 of this Part (20.2.74.501 NMAC) which emits or has the potential to emit stack emissions of less than two hundred fifty (250) tons per year of any regulated pollutant. As such, this regulation does not apply.
20.2.75 NMAC	Construction Permit Fees	Yes	Facility	This regulation applies if you are submitting an application pursuant to 20.2.72, 20.2.73, 20.2.74, and/or 20.2.79 NMAC. This facility is subject to 20.2.72; therefore this regulation applies.
20.2.77 NMAC	New Source Performance	Yes	1,2, and 3	Units 1, 2, and 3 are subject to federal source performance standards (NSPS) Dc since they were built after 1989 and are greater than 10 MMBtu/hr and less than 100 MMBtu/hr, therefore this regulation applies
20.2.78 NMAC	Emission Standards for HAPS	No	Units Subject to 40 CFR 61	This facility does not emits hazardous air pollutants which are subject to the requirements of 40 CFR Part 61.
20.2.79 NMAC	Permits – Nonattainment Areas	No	N/A	This facility is a minor stationary source located in an attainment/unclassifiable area. This regulation does not apply.
20.2.80 NMAC	Stack Heights	No	N/A	This regulation establishes requirements for the evaluation of stack heights and other dispersion techniques. This regulation does not apply as all stacks at the facility will follow good engineering practice. The objective of this part is to establish requirements for the evaluation of stack heights and other dispersion techniques in permitting decisions. This regulation does not apply
20.2.82 NMAC	MACT Standards for source categories of HAPS	Yes	Units Subject to 40 CFR 63	This regulation applies to all sources emitting hazardous air pollutants, which are subject to the requirements of 40 CFR Part 63. This facility contains sources subject to requirements under 40 CFR 63 therefore this regulation applies.

Table for Applicable Federal Regulations:

<u>Federal Regulation Citation</u>	Title	Applies? Enter Yes or No	Unit(s) or Facility	Justification:
40 CFR 50	NAAQS	Yes	Facility	This applies if you are subject to 20.2.70, 20.2.72, 20.2.74, and/or 20.2.79 NMAC. Facility is subject to 20.2.72 NMAC therefore this regulation applies
NSPS 40 CFR 60, Subpart A	General Provisions	Yes	Unit Subject to 40 CFR 60	The facility is subject to NSPS Dc; therefore this regulation does apply.
NSPS 40 CFR60.40a, Subpart Da	Subpart Da, Performance Standards for Electric Utility Steam Generating Units	No	N/A	The affected facility to which this subpart applies is each electric utility steam generating unit that is capable of combusting more than 73 megawatts (MW) (250 million British thermal units per hour (MMBtu/hr)) heat input of fossil fuel (either alone or in combination with any other fuel); and for which construction, modification, or reconstruction is commenced after September 18, 1978. This site does not contain the affected facility. This regulation does not apply.
NSPS 40 CFR60.40b Subpart Db	Electric Utility Steam Generating Units	No	N/A	The affected facility to which this subpart applies is each steam generating unit that commences construction, modification, or reconstruction after June 19, 1984, and that has a heat input capacity from fuels combusted in the steam generating unit of greater than 29 MW (100 million Btu/hour). This site does not contain the affected facility. This regulation does not apply.
40 CFR 60.40c, Subpart Dc	Standards of Performance for Small Industrial-Commercial-Institutional Steam Generating Units	Yes	1, 2, and 3	Units 1, 2, and 3 are subject to federal source performance standards (NSPS) Dc since they were built after 1989 and are greater than 10 MMBtu/hr and less than 100 MMBtu/hr, therefore this regulation applies.
NSPS 40 CFR 60, Subpart Ka	Standards of Performance for Storage Vessels for Petroleum Liquids for which Construction, Reconstruction, or Modification Commenced After May 18, 1978, and Prior to July 23, 1984	No	N/A	The affected facility to which this subpart applies is each storage vessel with a storage capacity greater than 151,416 liters (40,000 gallons) that is used to store petroleum liquids for which construction is commenced after May 18, 1978. This site does not contain the affected facility. This regulation does not apply
NSPS 40 CFR 60, Subpart Kb	Standards of Performance for Volatile Organic Liquid Storage Vessels (Including Petroleum Liquid Storage Vessels) for Which Construction, Reconstruction, or Modification Commenced After July 23, 1984	No	N/A	The affected facility to which this subpart applies is each storage vessel with a capacity greater than or equal to 75 cubic meters (m ³) that is used to store volatile organic liquids (VOL) for which construction, reconstruction, or modification is commenced after July 23, 1984. This site does not contain the affected facility. This regulation does not apply.

<u>Federal Regulation Citation</u>	Title	Applies? Enter Yes or No	Unit(s) or Facility	Justification:
NSPS 40 CFR 60.330 Subpart GG	Stationary Gas Turbines	No	N/A	The provisions of this subpart are applicable to the following affected facilities: All stationary gas turbines with a heat input at peak load equal to or greater than 10.7 gigajoules (10 million Btu) per hour, based on the lower heating value of the fuel fired. This site does not contain the affected facility. This regulation does not apply.
NSPS 40 CFR 60, Subpart KKK	Leaks of VOC from Onshore Gas Plants	No	N/A	Any affected facility under paragraph (a) of this section that commences construction, reconstruction, or modification after January 20, 1984, is subject to the requirements of this subpart. The group of all equipment (each pump, pressure relief device, open-ended valve or line, valve, compressor, and flange or other connector that is in VOC service or in wet gas service, and any device or system required by this subpart) except compressors (defined in § 60.631) within a process unit is an affected facility. A compressor station, dehydration unit, sweetening unit, underground storage tank, field gas gathering system, or liquefied natural gas unit is covered by this subpart if it is located at an onshore natural gas processing plant. If the unit is not located at the plant site, then it is exempt from the provisions of this subpart. This site does not contain the affected facility. This regulation does not apply.
NSPS 40 CFR Part 60 Subpart LLL	Standards of Performance for Onshore Natural Gas Processing: SO₂ Emissions	No	N/A	The provisions of this subpart are applicable to the following affected facilities that process natural gas: each sweetening unit, and each sweetening unit followed by a sulfur recovery unit. This site does not contain the affected facility. This regulation does not apply.
NSPS 40 CFR Part 60 Subpart OOOO	Standards of Performance for Crude Oil and Natural Gas Production, Transmission, and Distribution for which construction, modification or reconstruction commenced after August 23, 2011 and before September 18, 2015	No	N/A	The rule applies to “affected” facilities that are constructed, modified, or reconstructed after Aug 23, 2011 (40 CFR 60.5365): gas wells, including fractured and hydraulically refractured wells, centrifugal compressors, reciprocating compressors, pneumatic controllers, certain equipment at natural gas processing plants, sweetening units at natural gas processing plants, and storage vessels. The facility is not an affected facility; therefore, this regulation does not apply.
NSPS 40 CFR Part 60 Subpart OOOOa	Standards of Performance for Crude Oil and Natural Gas Facilities for which Construction, Modification or Reconstruction Commenced After September 18, 2015	No	N/A	The facility is not an affected facility under 40 CFR 60 OOOO and is therefore also not an affected facility under 40 CFR 60 OOOOa; therefore, this regulation does not apply.
NSPS 40 CFR 60 Subpart IIII	Standards of performance for Stationary Compression Ignition Internal Combustion Engines	No	N/A	The facility does not include any stationary compression ignition internal combustion engines; therefore, this regulation does not apply.

Federal Regulation Citation	Title	Applies? Enter Yes or No	Unit(s) or Facility	Justification:
NSPS 40 CFR Part 60 Subpart JJJJ	Standards of Performance for Stationary Spark Ignition Internal Combustion Engines	No	N/A	The facility does not include any stationary spark ignition internal combustion engines; therefore, this regulation does not apply.
NSPS 40 CFR 60 Subpart TTTT	Standards of Performance for Greenhouse Gas Emissions for Electric Generating Units	No	N/A	This subpart establishes emission standards and compliance schedules for the control of greenhouse gas (GHG) emissions from a steam generating unit, IGCC, or a stationary combustion turbine that commences construction after January 8, 2014 or commences modification or reconstruction after June 18, 2014. This site does not contain the affected facility. This regulation does not apply.
NSPS 40 CFR 60 Subpart UUUU	Emissions Guidelines for Greenhouse Gas Emissions and Compliance Times for Electric Utility Generating Units	No	N/A	This subpart establishes emission guidelines and approval criteria for State or multi-State plans that establish emission standards limiting greenhouse gas (GHG) emissions from an affected steam generating unit, integrated gasification combined cycle (IGCC), or stationary combustion turbine. This site does not contain the affected facility. This regulation does not apply.
NSPS 40 CFR 60, Subparts WWW, Cc, and Cf	Standards of performance for Municipal Solid Waste (MSW) Landfills	No	N/A	This facility is not a municipal solid waste landfill. This regulation does not apply.
NESHAP 40 CFR 61 Subpart A	General Provisions	No	N/A	Applies if any other Subpart in 40 CFR 61 applies. This facility is not subject to any standards under 40 CFR 61. This regulation does not apply.
NESHAP 40 CFR 61 Subpart E	National Emission Standards for Mercury	No	N/A	The provisions of this subpart are applicable to those stationary sources which process mercury ore to recover mercury, use mercury chlor-alkali cells to produce chlorine gas and alkali metal hydroxide, and incinerate or dry wastewater treatment plant sludge. This facility does not contain the affected processes. This regulation does not apply.
NESHAP 40 CFR 61 Subpart V	National Emission Standards for Equipment Leaks (Fugitive Emission Sources)	No	N/A	The provisions of this subpart apply to each of the following sources that are intended to operate in volatile hazardous air pollutant (VHAP) service: pumps, compressors, pressure relief devices, sampling connection systems, open-ended valves or lines, valves, connectors, surge control vessels, bottoms receivers, and control devices or systems required by this subpart. VHAP service means a piece of equipment either contains or contacts a fluid (liquid or gas) that is at least 10 percent by weight of VHAP. VHAP means a substance regulated under this subpart for which a standard for equipment leaks of the substance has been promulgated. There are no units which operate in VHAP service at this facility. This regulation does not apply
MACT 40 CFR 63, Subpart A	General Provisions	No	N/A	Applies if any other Subpart in 40 CFR 63 applies. This facility is not subject to any part of 40 CFR 63; therefore this regulation does not apply.
MACT 40 CFR 63.760 Subpart HH	Oil and Natural Gas Production Facilities	No	N/A	This subpart applies to the owners and operators of the emission points, specified in paragraph (b) of this section that are located at oil and natural gas production facilities that meet the specified criteria in paragraphs (a)(1) and either (a)(2) or (a)(3) of this section. This site does not contain emissions points located at oil and natural gas production facilities. This regulation does not apply.

<u>Federal Regulation Citation</u>	Title	Applies? Enter Yes or No	Unit(s) or Facility	Justification:
MACT 40 CFR 63 Subpart HHH	National Emission Standards for Hazardous Air Pollutants From Natural Gas Transmission and Storage Facilities	No	N/A	This subpart applies to owners and operators of natural gas transmission and storage facilities that transport or store natural gas prior to entering the pipeline to a local distribution company or to a final end user (if there is no local distribution company), and that are major sources of hazardous air pollutants (HAP) emissions as defined in §63.1271. This site does not contain the affected facility. This regulation does not apply.
MACT 40 CFR 63 Subpart DDDDD	National Emission Standards for Hazardous Air Pollutants for Major Industrial, Commercial, and Institutional Boilers & Process Heaters	No	N/A	This subpart establishes national emission limitations and work practice standards for hazardous air pollutants (HAP) emitted from industrial, commercial, and institutional boilers and process heaters located at major sources of HAP. This subpart also establishes requirements to demonstrate initial and continuous compliance with the emission limitations and work practice standards. This site does not contain the affected facility. This regulation does not apply.
MACT 40 CFR 63 Subpart UUUUU	National Emission Standards for Hazardous Air Pollutants Coal & Oil Fire Electric Utility Steam Generating Unit	No	N/A	This subpart establishes national emission limitations and work practice standards for hazardous air pollutants (HAP) emitted from coal- and oil-fired electric utility steam generating units (EGUs) as defined in § 63.10042 of this subpart. This subpart also establishes requirements to demonstrate initial and continuous compliance with the emission limitations. This site does not contain the affected facility. This regulation does not apply.
MACT 40 CFR 63 Subpart ZZZZ	National Emissions Standards for Hazardous Air Pollutants for Stationary Reciprocating Internal Combustion Engines (RICE MACT)	No	N/A	Subpart ZZZZ establishes national emission limitations and operating limitations for hazardous air pollutants (HAP) emitted from stationary reciprocating internal combustion engines (RICE) located at major and area sources of HAP emissions. This facility does not have any stationary reciprocating internal combustion engines; therefore, this regulation does not apply.
40 CFR 64	Compliance Assurance Monitoring	No	N/A	This regulation applies only to Title V major sources. This facility is not a Title V major source. This regulation does not apply.
40 CFR 68	Chemical Accident Prevention	No	N/A	This part sets forth the list of regulated substances and thresholds, the petition process for adding or deleting substances to the list of regulated substances, the requirements for owners or operators of stationary sources concerning the prevention of accidental releases, and the State accidental release prevention programs approved under section 112(r). This facility does not have more than a threshold quantity of a regulated substance in a process as determined under §68.115. This regulation does not apply.
Title IV – Acid Rain 40 CFR 72	Acid Rain	No	N/A	This facility does not generate commercial electric power or electric power for sale. This regulation does not apply.
Title IV – Acid Rain 40 CFR 73	Sulfur Dioxide Allowance Emissions	No	N/A	This facility does not generate commercial electric power or electric power for sale. This regulation does not apply.
Title IV-Acid Rain 40 CFR 75	Continuous Emissions Monitoring	No	N/A	This facility does not generate commercial electric power or electric power for sale. This regulation does not apply.

Title IV – Acid Rain 40 CFR 76	Acid Rain Nitrogen Oxides Emission Reduction Program	No	N/A	This facility does not generate commercial electric power or electric power for sale. This regulation does not apply.
Title VI – 40 CFR 82	Protection of Stratospheric Ozone	No	N/A	This regulation establishes requirements for protection of the stratospheric ozone. The regulation is not applicable because the facility does not “service”, “maintain” or “repair” class I or class II appliances nor “disposes” of the appliances [40 CFR Part 82.1(a)].

Section 14

Operational Plan to Mitigate Emissions

(Submitting under 20.2.70, 20.2.72, 20.2.74 NMAC)

- Title V Sources** (20.2.70 NMAC): By checking this box and certifying this application the permittee certifies that it has developed an **Operational Plan to Mitigate Emissions During Startups, Shutdowns, and Emergencies** defining the measures to be taken to mitigate source emissions during startups, shutdowns, and emergencies as required by 20.2.70.300.D.5(f) and (g) NMAC. This plan shall be kept on site to be made available to the Department upon request. This plan should not be submitted with this application.
- NSR** (20.2.72 NMAC), **PSD** (20.2.74 NMAC) & **Nonattainment** (20.2.79 NMAC) **Sources:** By checking this box and certifying this application the permittee certifies that it has developed an **Operational Plan to Mitigate Source Emissions During Malfunction, Startup, or Shutdown** defining the measures to be taken to mitigate source emissions during malfunction, startup, or shutdown as required by 20.2.72.203.A.5 NMAC. This plan shall be kept on site to be made available to the Department upon request. This plan should not be submitted with this application.
- Title V** (20.2.70 NMAC), **NSR** (20.2.72 NMAC), **PSD** (20.2.74 NMAC) & **Nonattainment** (20.2.79 NMAC) **Sources:** By checking this box and certifying this application the permittee certifies that it has established and implemented a Plan to Minimize Emissions During Routine or Predictable Startup, Shutdown, and Scheduled Maintenance through work practice standards and good air pollution control practices as required by 20.2.7.14.A and B NMAC. This plan shall be kept on site or at the nearest field office to be made available to the Department upon request. This plan should not be submitted with this application.
-

Tagawa Greenhouse Enterprises, LLC keeps all necessary documentation at the Tagawa Southwest facility. Startup and shutdown procedures are either based on manufacturer's recommendations or based on Tagawa's experience with specific equipment. These procedures are designed to proactively address the potential for malfunction to the greatest extent possible. These procedures dictate a sequence of operations that are designed to minimize emissions from the facility during events that result in shutdown and subsequent startup.

Equipment located at this facility is equipped with various safety devices and features that aid in the prevention of excess emissions in the event of an operational emergency. If an operational emergency does occur and excess emissions occur Tagawa will submit the required Excess Emissions Report per 20.2.7 NMAC if any emissions occur. However, SSM emissions are not expected as part of Tagawa operations.

Section 15

Alternative Operating Scenarios

(Submitting under 20.2.70, 20.2.72, 20.2.74 NMAC)

Alternative Operating Scenarios: Provide all information required by the department to define alternative operating scenarios. This includes process, material and product changes; facility emissions information; air pollution control equipment requirements; any applicable requirements; monitoring, recordkeeping, and reporting requirements; and compliance certification requirements. Please ensure applicable Tables in this application are clearly marked to show alternative operating scenario.

Construction Scenarios: When a permit is modified authorizing new construction to an existing facility, NMED includes a condition to clearly address which permit condition(s) (from the previous permit and the new permit) govern during the interval between the date of issuance of the modification permit and the completion of construction of the modification(s). There are many possible variables that need to be addressed such as: Is simultaneous operation of the old and new units permitted and, if so for example, for how long and under what restraints? In general, these types of requirements will be addressed in Section A100 of the permit, but additional requirements may be added elsewhere. Look in A100 of our NSR and/or TV permit template for sample language dealing with these requirements. Find these permit templates at: www.env.nm.gov/air-quality/permitting-section-procedures-and-guidance/. Compliance with standards must be maintained during construction, which should not usually be a problem unless simultaneous operation of old and new equipment is requested.

In this section, under the bolded title “Construction Scenarios”, specify any information necessary to write these conditions, such as: conservative-realistic estimated time for completion of construction of the various units, whether simultaneous operation of old and new units is being requested (and, if so, modeled), whether the old units will be removed or decommissioned, any PSD ramifications, any temporary limits requested during phased construction, whether any increase in emissions is being requested as SSM emissions or will instead be handled as a separate Construction Scenario (with corresponding emission limits and conditions, etc.

When natural gas is not available, diesel fuel may be used for the boilers (1,2, and 3). Diesel fuel usage will be limited to 10 hours per year.

Section 16

Air Dispersion Modeling

- 1) Minor Source Construction (20.2.72 NMAC) and Prevention of Significant Deterioration (PSD) (20.2.74 NMAC) ambient impact analysis (modeling): Provide an ambient impact analysis as required at 20.2.72.203.A(4) and/or 20.2.74.303 NMAC and as outlined in the Air Quality Bureau’s Dispersion Modeling Guidelines found on the Planning Section’s modeling website. If air dispersion modeling has been waived for one or more pollutants, attach the AQB Modeling Section modeling waiver approval documentation.
- 2) SSM Modeling: Applicants must conduct dispersion modeling for the total short term emissions during routine or predictable startup, shutdown, or maintenance (SSM) using realistic worst case scenarios following guidance from the Air Quality Bureau’s dispersion modeling section. Refer to "Guidance for Submittal of Startup, Shutdown, Maintenance Emissions in Permit Applications (http://www.env.nm.gov/aqb/permit/app_form.html) for more detailed instructions on SSM emissions modeling requirements.
- 3) Title V (20.2.70 NMAC) ambient impact analysis: Title V applications must specify the construction permit and/or Title V Permit number(s) for which air quality dispersion modeling was last approved. Facilities that have only a Title V permit, such as landfills and air curtain incinerators, are subject to the same modeling required for preconstruction permits required by 20.2.72 and 20.2.74 NMAC.

What is the purpose of this application?	Enter an X for each purpose that applies
New PSD major source or PSD major modification (20.2.74 NMAC). See #1 above.	
New Minor Source or significant permit revision under 20.2.72 NMAC (20.2.72.219.D NMAC). See #1 above. Note: Neither modeling nor a modeling waiver is required for VOC emissions.	X
Reporting existing pollutants that were not previously reported.	
Reporting existing pollutants where the ambient impact is being addressed for the first time.	
Title V application (new, renewal, significant, or minor modification. 20.2.70 NMAC). See #3 above.	
Relocation (20.2.72.202.B.4 or 72.202.D.3.c NMAC)	
Minor Source Technical Permit Revision 20.2.72.219.B.1.d.vi NMAC for like-kind unit replacements.	
Other: i.e. SSM modeling. See #2 above.	
This application does not require modeling since this is a No Permit Required (NPR) application.	
This application does not require modeling since this is a Notice of Intent (NOI) application (20.2.73 NMAC).	
This application does not require modeling according to 20.2.70.7.E(11), 20.2.72.203.A(4), 20.2.74.303, 20.2.79.109.D NMAC and in accordance with the Air Quality Bureau’s Modeling Guidelines.	

Check each box that applies:

- See attached, approved modeling **waiver for all** pollutants from the facility.
- See attached, approved modeling **waiver for some** pollutants from the facility.
- Attached in Universal Application Form 4 (UA4) is a **modeling report for all** pollutants from the facility.
- Attached in UA4 is a **modeling report for some** pollutants from the facility.
- No modeling is required.

From: [Adam Erenstein](#)
To: [Mustafa, Sufi A., NMENV](#)
Cc: [Jaimy Karacaoglu](#); [Bill Kluth](#)
Subject: Tagawa Southwest Modeling Protocol
Date: Friday, September 9, 2022 1:54:53 PM
Attachments: [Tagawa Greenhouse Modeling Protocol v1.0 2022 0909.pdf](#)
[image001.png](#)

Hi Sufi,

Tagawa is submitting an application pursuant to 20.2.72.219.D.1.a NMAC for significant revision of NSR Permit 2128-M1. The purpose of this revision is to remove Boiler #2 at the facility, which is no longer operational, and add two new boilers.

Tagawa seeks to demonstrate compliance with the National Ambient Air Quality Standards (NAAQS) and the New Mexico Ambient Air Quality Standards (NMAAQS) as applicable for the following pollutants and averaging periods: NO₂ (1-hour and annual), CO (1-hour and 8-hour), PM₁₀ (24-hour and annual), PM_{2.5} (24-hour), and SO₂ (1-hour, 3-hour, 24-hour, and annual).

Attached is the modeling protocol for your review. Please contact me if you have any questions. Have a great weekend!

Regards,

Adam Erenstein

Principal Consultant, Manager of Consulting Services

P 505.266.6611 M 480.760.3860

NEW ADDRESS: 9400 Holly Avenue NE, Building 3, Suite B, Albuquerque, NM 87122

Email: aerenstein@trinityconsultants.com



Connect with us: [LinkedIn](#) / [Facebook](#) / [Twitter](#) / [YouTube](#) / trinityconsultants.com

Stay current on environmental issues. [Subscribe](#) today to receive Trinity's free *EHS Quarterly*.

AIR DISPERSION MODELING PROTOCOL

NSR Significant Revision Modeling Protocol

Tagawa Greenhouse Enterprises LLC **Tagawa Southwest - Estancia**

Prepared By:

Adam Erenstein – Manager of Consulting Services

TRINITY CONSULTANTS

9400 Holly Ave NE
Building 3, Suite B
Albuquerque, NM 87122
(505) 266-6611

September 2022

Project 223201.0151



1. INTRODUCTION

1.1 Purpose of Modeling

Tagawa Southwest is an enclosed greenhouse owned and operated by Tagawa Greenhouse Enterprises LLC (Tagawa). The primary purpose of the facility is the annual bedding plants and perennials for wholesale distribution to other greenhouse companies and retailers. The greenhouse is located approximately 6 miles southwest of Estancia in Torrance County, New Mexico.

Tagawa is submitting an application pursuant to 20.2.72.219.D.1.a NMAC for significant revision of NSR Permit 2128-M1. The purpose of this revision is to remove Boiler #2 at the facility, which is no longer operational, and add two new boilers.

Tagawa seeks to demonstrate compliance with the National Ambient Air Quality Standards (NAAQS) and the New Mexico Ambient Air Quality Standards (NMAAQS) as applicable for the following pollutants and averaging periods: NO₂ (1-hour and annual), CO (1-hour and 8-hour), PM₁₀ (24-hour and annual), PM_{2.5} (24-hour), and SO₂ (1-hour, 3-hour, 24-hour, and annual).

1.2 Facility Description and Location

The UTM coordinates of the facility are 400,840 meters East and 3,837,090 meters North in UTM Zone 13 with WGS 84 datum at an elevation of approximately 6149 feet above mean sea level.

2. PROPOSED MODELING

2.1 Model Input Options

The latest version of the AERMOD dispersion model (version 22112) will be used for this analysis. The model will be run in regulatory mode with all default options. The ARM2 method will be used to convert NO_x to NO₂. Default minimum and maximum ambient ratios will be utilized.

The boilers (both new and existing) will only fire diesel fuel in emergency situations when firing of natural gas is not possible. Burning diesel backup fuel in the boilers at Tagawa (even to prepare for emergencies) has historically never occurred. The boilers do not fire diesel fuel except in emergency situations, therefore the emissions used in the air dispersion modeling will be based on the combustion of natural gas.

This assumption was made in accordance with guidance provided in the EPA Memo entitled: "Additional Clarification Regarding Application of Appendix W Modeling Guidance for the 1-hour NO₂ National Ambient Air Quality Standard" (March, 1 2011). The memo notes the following:

"Given the implications of the probabilistic form of the 1-hour NO₂ NAAQS discussed above, we are concerned that assuming continuous operations for intermittent emissions would effectively impose an additional level of stringency beyond that intended by the level of the standard itself. As a result, we feel that it would be inappropriate to implement the 1-hour NO₂ standard in such a manner and recommend that compliance demonstrations for the 1-hour NO₂ NAAQS be based on emission scenarios that can logically be assumed to be relatively continuous or which occur frequently enough to contribute significantly to the annual distribution of daily maximum 1-hour concentrations. EPA believes that existing modeling guidelines provide sufficient discretion for reviewing authorities to exclude certain types of intermittent emissions from compliance demonstrations for the 1-hour NO₂ standard under these circumstances."

As emissions from diesel combustion in these dual-fuel boilers (both existing and new) are extremely rare, Tagawa has designated their diesel-fired operation as intermittent in nature and therefore has based the compliance demonstration on the combustion of natural gas. Table 1 shows the emission sources that will be modeled.

Table 1 Emission sources and stack parameters to be included in the air dispersion modeling.

Equipment	NO _x lb/hr	CO lb/hr	SO _x lb/hr	PM ₁₀ lb/hr	PM _{2.5} lb/hr	Height ft	Temp ¹ K	Velocity ft/s	Diam. in.
Boiler #1	2.21	3.71	0.25	0.34	0.34	29.25	500	124.87	27.5
Boiler #2	2.06	1.73	0.12	0.16	0.16	29.08	500	56.17	27.5
Boiler #3	2.06	1.73	0.12	0.16	0.16	29.08	500	56.17	27.5

¹ Stack temperature from Table 40: Missing Stack Parameter Substitutions for Other Point Sources from the NMED Air Dispersion Modeling Guidance.

A downwash analysis using the latest version of BPIP will be conducted and incorporated into the modeling analysis to account for potential effluent downwash due to structures at the facility.

2.2 Receptor Grid Description and Elevation Data

The center point of the facility will be designated at 400,840 meters East and 3,837,090 meters North. This center point will serve as the center point for a variable density circular receptor grid. The following defines the receptor grids utilized:

1. The facility fence line will be modeled using 50-meter grid spacing.
2. The "fine grid" will contain 100-meter spaced receptors extending about 500 meters from the facility fence line in areas of greater potential for higher impacts. This 100-meter spacing will be used in accordance with guidance for boundaries of expansive sources in Section 4.6.3 of the Modeling Guidelines.
3. The "medium grid" will contain 500-meter spaced receptors extending about 3 km from the property line grid, excluding the fine grid.
4. The "medium-coarse grid" will contain 1,000-meter spaced receptors extending about 6 km from the property line grid, excluding the fine and medium grids.
5. The "coarse grid" will contain 5,000-meter spaced receptors extending to a maximum 50 km from the facility center point, excluding the fine and medium/medium-coarse grids.

The elevations of receptors and facility sources will be determined using the most recent DEM data currently available. It is expected that the highest impacts from the proposed source will be at or near the facility property.

2.3 Meteorological Data

We will use the Bernalillo 2011 meteorological data set available on the NMED website. This meteorological data set is located in comparable terrain and within the same general region of New Mexico with a comparable climate. Therefore, this data is representative of meteorological conditions at the facility.

2.4 Significance Analysis and Cumulative Impact Analysis (CIA)

The modeled ground-level concentrations will be compared to the corresponding significant impact levels (SILs) to determine whether any modeled ground-level concentrations at any receptor locations are greater than the SIL (i.e., "significant" receptors). If the significance analysis reveals that modeled ground-level concentrations for a particular pollutant and averaging period are greater than the applicable SIL, a Cumulative Impact Analysis (CIA) will be performed at the significant receptors.

If significant, the CIA will be performed including impacts from the facility sources and background concentrations. If necessary, the background concentration used for NO₂, CO, PM₁₀, and PM_{2.5} will be from the Del Norte High School Monitor (350010023) and the background concentration used for SO₂ will be the Bloomfield Monitor (1ZB). The inclusion of background concentrations will follow the guidance shown in Table 6C: "Modeling the Design Value Summary (Default Modeling)" from the Modeling Guidelines.

2.5 PSD Increment Analysis

The facility is located in Air Quality Control Region (AQCR) 154. AQCR 154 has no established minor source baseline dates; therefore, neither PSD Class I nor Class II modeling is required.

Section 17

Compliance Test History

(Submitting under 20.2.70, 20.2.72, 20.2.74 NMAC)

To show compliance with existing NSR permits conditions, you must submit a compliance test history. The table below provides an example.

To save paper and to standardize the application format, delete this sentence and the samples in the Compliance Test History Table, and begin your submittal for this attachment on this page.

Compliance Test History Table

Unit No.	Test Description	Test Date
1,2	Tested in accordance with EPA test methods for NOx and CO as required by Title V permit P500.	4/13/2004
3	Tested in accordance with EPA test methods for NOx and CO as required by NSR permit 2923M1.	5/12/2005

Section 20

Other Relevant Information

Other relevant information. Use this attachment to clarify any part in the application that you think needs explaining. Reference the section, table, column, and/or field. Include any additional text, tables, calculations or clarifying information.

Additionally, the applicant may propose specific permit language for AQB consideration. In the case of a revision to an existing permit, the applicant should provide the old language and the new language in track changes format to highlight the proposed changes. If proposing language for a new facility or language for a new unit, submit the proposed operating condition(s), along with the associated monitoring, recordkeeping, and reporting conditions. In either case, please limit the proposed language to the affected portion of the permit.

No other relevant information is being submitted.

Change Log – Do **not** submit this page with your application.

If you are using a form older than the most current form posted on the website, you are required to incorporate the changes listed. Periodically, AQB will announce when older form versions will no longer be accepted.

Version Date	Changes Incorporated
Section 3 – 6/14/2019	8/11/2022: Section 13 updated to include 20.2.50 NMAC.
Section 4 – 8/15/2011	
Section 5 – 8/15/2011	This Change Log page was added.
Section 6 – 5/13/2016	The dates for each section’s last update are listed.
Section 6a – 5/13/2016	
Section 7 – 8/15/2011	
Section 8 – 8/15/2011	
Section 9 – 8/15/2011	
Section 10 – 8/15/2011	
Section 11 – 10/26/2011	
Section 12 – 5/19/2019	
Section 13 – 8/11/2022	
Section 14 – 8/15/2011	
Section 15 – 8/15/2011	
Section 16 – 5/3/2016	
Section 17 – 8/15/2011	
Section 18 – 3/9/2012	
Section 19 – 8/15/2011	
Section 20 – 8/15/2011	
Section 21 – 10/4/2016	
Section 22 – 3/7/2016	

Universal Application 4

Air Dispersion Modeling Report

Refer to and complete Section 16 of the Universal Application form (UA3) to assist your determination as to whether modeling is required. If, after filling out Section 16, you are still unsure if modeling is required, e-mail the completed Section 16 to the AQB Modeling Manager for assistance in making this determination. If modeling is required, a modeling protocol would be submitted and approved prior to an application submittal. The protocol should be emailed to the modeling manager. A protocol is recommended but optional for minor sources and is required for new PSD sources or PSD major modifications. Fill out and submit this portion of the Universal Application form (UA4), the "Air Dispersion Modeling Report", only if air dispersion modeling is required for this application submittal. This serves as your modeling report submittal and should contain all the information needed to describe the modeling. No other modeling report or modeling protocol should be submitted with this permit application.

16-A: Identification		
1	Name of facility:	Tagawa Southwest
2	Name of company:	Tagawa Greenhouse Enterprises LLC
3	Current Permit number:	2128-M1-R1
4	Name of applicant's modeler:	Adam Erenstein
5	Phone number of modeler:	505-266-6611
6	E-mail of modeler:	aerenstein@trinityconsultants.com

16-B: Brief		
1	Was a modeling protocol submitted and approved?	Yes <input type="checkbox"/> No <input checked="" type="checkbox"/>
2	Why is the modeling being done?	Adding New Equipment
3	Describe the permit changes relevant to the modeling. The purpose of this revision is to remove Boiler #2 at the facility, which is no longer operational, and add two new boilers.	
4	What geodetic datum was used in the modeling?	WGS84
5	How long will the facility be at this location?	Greater than 1 year.
6	Is the facility a major source with respect to Prevention of Significant Deterioration (PSD)?	Yes <input type="checkbox"/> No <input checked="" type="checkbox"/>
7	Identify the Air Quality Control Region (AQCR) in which the facility is located	154

8	List the PSD baseline dates for this region (minor or major, as appropriate).		
	NO2	Not established	
	SO2	Not established	
	PM10	Not established	
	PM2.5	Not established	
9	Provide the name and distance to Class I areas within 50 km of the facility (300 km for PSD permits).		
	N/A – no Class I areas within 50 km.		
10	Is the facility located in a non-attainment area? If so describe below	Yes <input type="checkbox"/>	No <input checked="" type="checkbox"/>
	N/A		
11	Describe any special modeling requirements, such as streamline permit requirements.		
	N/A		

16-C: Modeling History of Facility

1	Describe the modeling history of the facility, including the air permit numbers, the pollutants modeled, the National Ambient Air Quality Standards (NAAQS), New Mexico AAQS (NMAAQs), and PSD increments modeled. (Do not include modeling waivers).			
	Pollutant	Latest permit and modification number that modeled the pollutant facility-wide.	Date of Permit	Comments
	CO			
	NO ₂			
	SO ₂			
	H ₂ S			Pollutant not emitted
	PM2.5			
	PM10			
	Lead			Pollutant not emitted
	Ozone (PSD only)			Pollutant not emitted
NM Toxic Air Pollutants (20.2.72.402 NMAC)			Pollutant not emitted	

16-D: Modeling performed for this application

1	For each pollutant, indicate the modeling performed and submitted with this application. Choose the most complicated modeling applicable for that pollutant, i.e., culpability analysis assumes ROI and cumulative analysis were also performed.					
	Pollutant	ROI	Cumulative analysis	Culpability analysis	Waiver approved	Pollutant not emitted or not changed.
	CO	<input checked="" type="checkbox"/>	<input type="checkbox"/>	<input type="checkbox"/>	<input type="checkbox"/>	<input type="checkbox"/>
	NO ₂	<input checked="" type="checkbox"/>	<input checked="" type="checkbox"/>	<input type="checkbox"/>	<input type="checkbox"/>	<input type="checkbox"/>
	SO ₂	<input checked="" type="checkbox"/>	<input type="checkbox"/>	<input type="checkbox"/>	<input type="checkbox"/>	<input type="checkbox"/>

	H ₂ S	<input type="checkbox"/>	<input type="checkbox"/>	<input type="checkbox"/>	<input type="checkbox"/>	<input checked="" type="checkbox"/>
	PM _{2.5}	<input checked="" type="checkbox"/>	<input type="checkbox"/>	<input type="checkbox"/>	<input type="checkbox"/>	<input type="checkbox"/>
	PM ₁₀	<input checked="" type="checkbox"/>	<input type="checkbox"/>	<input type="checkbox"/>	<input type="checkbox"/>	<input type="checkbox"/>
	Lead	<input type="checkbox"/>	<input type="checkbox"/>	<input type="checkbox"/>	<input type="checkbox"/>	<input checked="" type="checkbox"/>
	Ozone	<input type="checkbox"/>	<input type="checkbox"/>	<input type="checkbox"/>	<input type="checkbox"/>	<input checked="" type="checkbox"/>
	State air toxic(s) (20.2.72.402 NMAC)	<input type="checkbox"/>	<input type="checkbox"/>	<input type="checkbox"/>	<input type="checkbox"/>	<input checked="" type="checkbox"/>

16-E: New Mexico toxic air pollutants modeling

1	List any New Mexico toxic air pollutants (NMTAPs) from Tables A and B in 20.2.72.502 NMAC that are modeled for this application. N/A – NMTAPs are not emitted at this facility.					
2	List any NMTAPs that are emitted but not modeled because stack height correction factor. Add additional rows to the table below, if required.					
	Pollutant	Emission Rate (pounds/hour)	Emission Rate Screening Level (pounds/hour)	Stack Height (meters)	Correction Factor	Emission Rate/ Correction Factor

16-F: Modeling options

1	Was the latest version of AERMOD used with regulatory default options? If not explain below.	Yes <input checked="" type="checkbox"/>	No <input type="checkbox"/>
	N/A		

16-G: Surrounding source modeling

1	Date of surrounding source retrieval	N/A – Background was used cumulative analysis.
2	If the surrounding source inventory provided by the Air Quality Bureau was believed to be inaccurate, describe how the sources modeled differ from the inventory provided. If changes to the surrounding source inventory were made, use the table below to describe them. Add rows as needed.	
	AQB Source ID	Description of Corrections

16-H: Building and structure downwash

1	How many buildings are present at the facility?	2	
2	How many above ground storage tanks are present at the facility?	0	
	Was building downwash modeled for all buildings and tanks? If not explain why below.	Yes <input checked="" type="checkbox"/>	No <input type="checkbox"/>

3	N/A	
4	Building comments	N/A

16-I: Receptors and modeled property boundary

1	<p>“Restricted Area” is an area to which public entry is effectively precluded. Effective barriers include continuous fencing, continuous walls, or other continuous barriers approved by the Department, such as rugged physical terrain with a steep grade that would require special equipment to traverse. If a large property is completely enclosed by fencing, a restricted area within the property may be identified with signage only. Public roads cannot be part of a Restricted Area. A Restricted Area is required in order to exclude receptors from the facility property. If the facility does not have a Restricted Area, then receptors shall be placed within the property boundaries of the facility.</p> <p>Describe the fence or other physical barrier at the facility that defines the restricted area.</p> <p>The restricted area is defined by fencing.</p>					
2	Receptors must be placed along publicly accessible roads in the restricted area. Are there public roads passing through the restricted area?				Yes <input type="checkbox"/>	No <input checked="" type="checkbox"/>
3	Are restricted area boundary coordinates included in the modeling files?				Yes <input checked="" type="checkbox"/>	No <input type="checkbox"/>
4	Describe the receptor grids and their spacing. The table below may be used, adding rows as needed.					
	Grid Type	Shape	Spacing	Start distance from restricted area or center of facility	End distance from restricted area or center of facility	Comments
	Fine Grid	Square	100 m	0 m	1,350 m	From center of facility
	Medium Grid	Square	500 m	1,350 m	3,850 m	
	Medium-Coarse Grid	Square	1000 m	3,850 m	6,850 m	
	Coarse Grid	Square	5000 m	6,850 m	50,000 m	
5	Describe receptor spacing along the fence line.					
	Boundary receptor spacing is 50 meters as described in Section 4.6.3 of the Modeling Guidelines.					
6	Describe the PSD Class I area receptors.					
	N/A					

16-J: Sensitive areas

1	Are there schools or hospitals or other sensitive areas near the facility? If so describe below. This information is optional (and purposely undefined) but may help determine issues related to public notice.	Yes <input type="checkbox"/>	No <input checked="" type="checkbox"/>
---	---	------------------------------	--

	N/A		
3	The modeling review process may need to be accelerated if there is a public hearing. Are there likely to be public comments opposing the permit application?	Yes <input type="checkbox"/>	No <input checked="" type="checkbox"/>

16-K: Modeling Scenarios

1	Identify, define, and describe all modeling scenarios. Examples of modeling scenarios include using different production rates, times of day, times of year, simultaneous or alternate operation of old and new equipment during transition periods, etc. Alternative operating scenarios should correspond to all parts of the Universal Application and should be fully described in Section 15 of the Universal Application (UA3).										
	The facility does not have an alternative operating scenario.										
2	Which scenario produces the highest concentrations? Why?										
	N/A										
3	Were emission factor sets used to limit emission rates or hours of operation? (This question pertains to the "SEASON", "MONTH", "HROFDY" and related factor sets, not to the factors used for calculating the maximum emission rate.)									Yes <input type="checkbox"/>	No <input checked="" type="checkbox"/>
4	If so, describe factors for each group of sources. List the sources in each group before the factor table for that group. (Modify or duplicate table as necessary. It's ok to put the table below section 16-K if it makes formatting easier.) Sources: N/A										
5	Hour of Day	Factor	Hour of Day	Factor							
	1		13								
	2		14								
	3		15								
	4		16								
	5		17								
	6		18								
	7		19								
	8		20								
	9		21								
	10		22								
	11		23								
	12		24								
	If hourly, variable emission rates were used that were not described above, describe them below.										
N/A											
6	Were different emission rates used for short-term and annual modeling? If so describe below.									Yes <input type="checkbox"/>	No <input checked="" type="checkbox"/>
	N/A										

16-L: NO₂ Modeling

	Which types of NO ₂ modeling were used?
--	--

1	Check all that apply.		
	<input checked="" type="checkbox"/>	ARM2	
	<input type="checkbox"/>	100% NO _x to NO ₂ conversion	
	<input type="checkbox"/>	PVMRM	
	<input type="checkbox"/>	OLM	
	<input type="checkbox"/>	Other:	
2	Describe the NO ₂ modeling.		
	NO ₂ was modeled using ARM2 in regulatory default mode.		
3	Were default NO ₂ /NO _x ratios (0.5 minimum, 0.9 maximum or equilibrium) used? If not describe and justify the ratios used below.		Yes <input checked="" type="checkbox"/>
	N/A		No <input type="checkbox"/>
4	Describe the design value used for each averaging period modeled.		
	1-hour: High first high Annual: One Year Annual Average		

16-M: Particulate Matter Modeling

1	Select the pollutants for which plume depletion modeling was used.		
	<input type="checkbox"/>	PM2.5	
	<input type="checkbox"/>	PM10	
	<input checked="" type="checkbox"/>	None	
2	Describe the particle size distributions used. Include the source of information.		
	N/A		
3	Does the facility emit at least 40 tons per year of NO _x or at least 40 tons per year of SO ₂ ? Sources that emit at least 40 tons per year of NO _x or at least 40 tons per year of SO ₂ are considered to emit significant amounts of precursors and must account for secondary formation of PM2.5.		Yes <input type="checkbox"/>
4	Was secondary PM modeled for PM2.5?		No <input checked="" type="checkbox"/>
5	If MERPs were used to account for secondary PM2.5 fill out the information below. If another method was used describe below.		
	NO _x (ton/yr)	SO ₂ (ton/yr)	[PM2.5] _{annual}
			[PM2.5] _{24-hour}
	N/A		

16-N: Setback Distances

1	Portable sources or sources that need flexibility in their site configuration requires that setback distances be determined between the emission sources and the restricted area boundary (e.g. fence line) for both the initial location and future locations. Describe the setback distances for the initial location.
	N/A – No setback distance used.
2	Describe the requested, modeled, setback distances for future locations, if this permit is for a portable stationary source. Include a haul road in the relocation modeling.
	N/A – No setback distance used.

16-O: PSD Increment and Source IDs

1	The unit numbers in the Tables 2-A, 2-B, 2-C, 2-E, 2-F, and 2-I should match the ones in the modeling files. Do these match? If not, provide a cross-reference table between unit numbers if they do not match below.		Yes <input type="checkbox"/>	No <input checked="" type="checkbox"/>	
	Unit Number in UA-2		Unit Number in Modeling Files		
	1		BL1		
	2		BL2		
	3		BL3		
2	The emission rates in the Tables 2-E and 2-F should match the ones in the modeling files. Do these match? If not, explain why below.		Yes <input checked="" type="checkbox"/>	No <input type="checkbox"/>	
	N/A				
3	Have the minor NSR exempt sources or Title V Insignificant Activities" (Table 2-B) sources been modeled?		Yes <input type="checkbox"/>	No <input checked="" type="checkbox"/>	
4	Which units consume increment for which pollutants? The facility is located in AQCR 154 which has yet to establish minor source baseline dates for NO ₂ , SO ₂ , PM ₁₀ , and PM _{2.5} ; therefore, PSD increment modeling is not applicable.				
	Unit ID	NO ₂	SO ₂	PM10	PM2.5
5	PSD increment description for sources. (for unusual cases, i.e., baseline unit expanded emissions after baseline date).				
6	Are all the actual installation dates included in Table 2A of the application form, as required? This is necessary to verify the accuracy of PSD increment modeling. If not please explain how increment consumption status is determined for the missing installation dates below.		Yes <input checked="" type="checkbox"/>	No <input type="checkbox"/>	

16-P: Flare Modeling

1	For each flare or flaring scenario, complete the following			
	Flare ID (and scenario)	Average Molecular Weight	Gross Heat Release (cal/s)	Effective Flare Diameter (m)
	N/A – No flares are located at this facility.			

16-Q: Volume and Related Sources			
1	Were the dimensions of volume sources different from standard dimensions in the Air Quality Bureau (AQB) Modeling Guidelines?	Yes <input type="checkbox"/>	No <input type="checkbox"/>
	If not please explain how increment consumption status is determined for the missing installation dates below. N/A – No volume sources at this facility.		
2	Describe the determination of sigma-Y and sigma-Z for fugitive sources.		
	N/A – No fugitive sources at this facility.		
3	Describe how the volume sources are related to unit numbers. Or say they are the same.		
	N/A – No volume sources at this facility.		
4	Describe any open pits.		
	N/A – No open pit sources at this facility.		
5	Describe emission units included in each open pit.		
	N/A – No open pit sources at this facility.		

16-R: Background Concentrations			
1	Were NMED provided background concentrations used? Identify the background station used below. If non-NMED provided background concentrations were used describe the data that was used.	Yes <input checked="" type="checkbox"/>	No <input type="checkbox"/>
	CO: N/A		
	NO ₂ : Del Norte High School (350010023)		
	PM2.5: N/A		
	PM10: N/A		
	SO ₂ : N/A		
	Other:		
	Comments:	N/A	
2	Were background concentrations refined to monthly or hourly values? If so describe below.	Yes <input type="checkbox"/>	No <input checked="" type="checkbox"/>
	N/A		

16-S: Meteorological Data			
1	Was NMED provided meteorological data used? If so select the station used.	Yes <input checked="" type="checkbox"/>	No <input type="checkbox"/>

2	If NMED provided meteorological data was not used describe the data set(s) used below. Discuss how missing data were handled, how stability class was determined, and how the data were processed.		
	The Bernalillo 2011 meteorological set provided by the NMED is used for this modeling analysis. This data set is representative of the area surrounding the facility in central New Mexico near Torrance County, New Mexico.		

16-T: Terrain

1	Was complex terrain used in the modeling? If not, describe why below.	Yes <input type="checkbox"/>	No <input checked="" type="checkbox"/>
	N/A - There is no complex terrain near the facility.		
2	What was the source of the terrain data?		
	N/A - There is no complex terrain near the facility.		

16-U: Modeling Files

1	Describe the modeling files:		
	File name (or folder and file name)	Pollutant(s)	Purpose (ROI/SIA, cumulative, culpability analysis, other)
	SO2 SIL v1.0 2022 0915	SO ₂	ROI/SIA
	CO SIL v1.0 2022 0915	CO	ROI/SIA
	PM10 SIL v1.0 2022 0915	PM ₁₀	ROI/SIA
	PM2.5 SIL v1.0 2022 0915	PM _{2.5}	ROI/SIA
	NO2 Hourly CIA v1.0 2022 0915	NO ₂	Cumulative
	NO2 Annual CIA v1.0 2022 0915	NO ₂	Cumulative

16-V: PSD New or Major Modification Applications -N/A

1	A new PSD major source or a major modification to an existing PSD major source requires additional analysis. Was preconstruction monitoring done (see 20.2.74.306 NMAC and PSD Preapplication Guidance on the AQB website)?	Yes <input type="checkbox"/>	No <input type="checkbox"/>
2	If not, did AQB approve an exemption from preconstruction monitoring?	Yes <input type="checkbox"/>	No <input type="checkbox"/>
3	Describe how preconstruction monitoring has been addressed or attach the approved preconstruction monitoring or monitoring exemption.		

4	Describe the additional impacts analysis required at 20.2.74.304 NMAC.		
5	If required, have ozone and secondary PM2.5 ambient impacts analyses been completed? If so describe below.	Yes <input type="checkbox"/>	No <input type="checkbox"/>

16-W: Modeling Results										
1	If ambient standards are exceeded because of surrounding sources, a culpability analysis is required for the source to show that the contribution from this source is less than the significance levels for the specific pollutant. Was culpability analysis performed? If so describe below.							Yes <input type="checkbox"/>	No <input checked="" type="checkbox"/>	
	N/A									
2	Identify the maximum concentrations from the modeling analysis. Rows may be modified, added and removed from the table below as necessary.									
Pollutant, Time Period and Standard	Modeled Facility Concentration (µg/m3)	Modeled Concentration with Surrounding Sources (µg/m3)	Secondary PM (µg/m3)	Background Concentration (µg/m3)	Cumulative Concentration (µg/m3)	Value of Standard (µg/m3)	Percent of Standard	Location		
								UTM E (m)	UTM N (m)	Elevation (m)
CO, 8-hr Significance	17.63	N/A	N/A	N/A	17.63	500	3.53%	401,161	3,836,916.3	1,869
CO, 1-hr Significance	65.60	N/A	N/A	N/A	65.60	2,000	3.28%	401,175	3,837,264.8	1,869
NO ₂ , 1-hr NAAQS	29.90	29.90	N/A	81.20	111.10	188.03	59.1%	401,175	3,837,264.8	1,869
NO ₂ , 24-hr NAAQS	7.99	N/A	N/A	N/A	7.99	Compliance with standard demonstrated with 1-hr NO ₂ model.				
NO ₂ , Annual NAAQS	1.21	1.21	N/A	17.20	18.41	94.02	18.5%	400,708	3,836,672.8	1,871.46
PM ₁₀ , Annual Significance	0.12	N/A	N/A	N/A	0.12	1	12.24%	400,708	3,836,672.8	1,871.46
PM ₁₀ , 24-hr Significance	0.85	N/A	N/A	N/A	0.85	5	16.93%	400,708	3,836,672.8	1,871.46
PM _{2.5} , Annual Significance	0.12	N/A	N/A	N/A	0.12	0.2	61.19%	400,708	3,836,672.8	1,871.46
PM _{2.5} , 24-hr Significance	0.85	N/A	N/A	N/A	0.85	1.2	70.52%	400,708	3,836,672.8	1,871.46
SO ₂ , 1-hr Significance	4.5	N/A	N/A	N/A	4.5	7.8	57.59%	401,175	3,837,264.8	1,869

Pollutant, Time Period and Standard	Modeled Facility Concentration (µg/m3)	Modeled Concentration with Surrounding Sources (µg/m3)	Secondary PM (µg/m3)	Background Concentration (µg/m3)	Cumulative Concentration (µg/m3)	Value of Standard (µg/m3)	Percent of Standard	Location		
								UTM E (m)	UTM N (m)	Elevation (m)
SO ₂ , 3-hr Significance	1.77	N/A	N/A	N/A	1.77	25	7.08%	400,378	3,836,941.1	1,873.82
SO ₂ , 24-hr Significance	0.63	N/A	N/A	N/A	0.63	5	12.60%	400,708	3,836,672.8	1,871.46
SO ₂ , Annual Significance	0.091	N/A	N/A	N/A	0.091	1	9.13%	400,708	3,836,672.8	1,871.5

16-X: Summary/conclusions

1	A statement that modeling requirements have been satisfied and that the permit can be issued.
	This modeling analysis has shown that the facility meets all applicable modeling standards. The permit can be issued.

Section 22: Certification

Company Name: Tagawa Greenhouse Enterprises LLC

I, WILLIAM A KUTZ, hereby certify that the information and data submitted in this application are true and as accurate as possible, to the best of my knowledge and professional expertise and experience.

Signed this 13 day of SEPTEMBER 2022 upon my oath or affirmation, before a notary of the State of

COLORADO

[Signature]
*Signature

09.13.2022
Date

WILLIAM A KUTZ
Printed Name

GM
Title

Scribed and sworn before me on this 13 day of September, 2022.

My authorization as a notary of the State of Colorado expires on the

15 day of December, 2025.

[Signature]
Notary's Signature

9/13/22
Date

Robert M. Loera
Notary's Printed Name

Robert Manuel Loera
NOTARY PUBLIC
STATE OF COLORADO
NOTARY ID 20174035838
MY COMMISSION EXPIRES December 15 2025

*For Title V applications, the signature must be of the Responsible Official as defined in 20.2.70.7.AE NMAC.